

Congestion management of MV/LV distribution grid

Hierarchical and distributed architecture

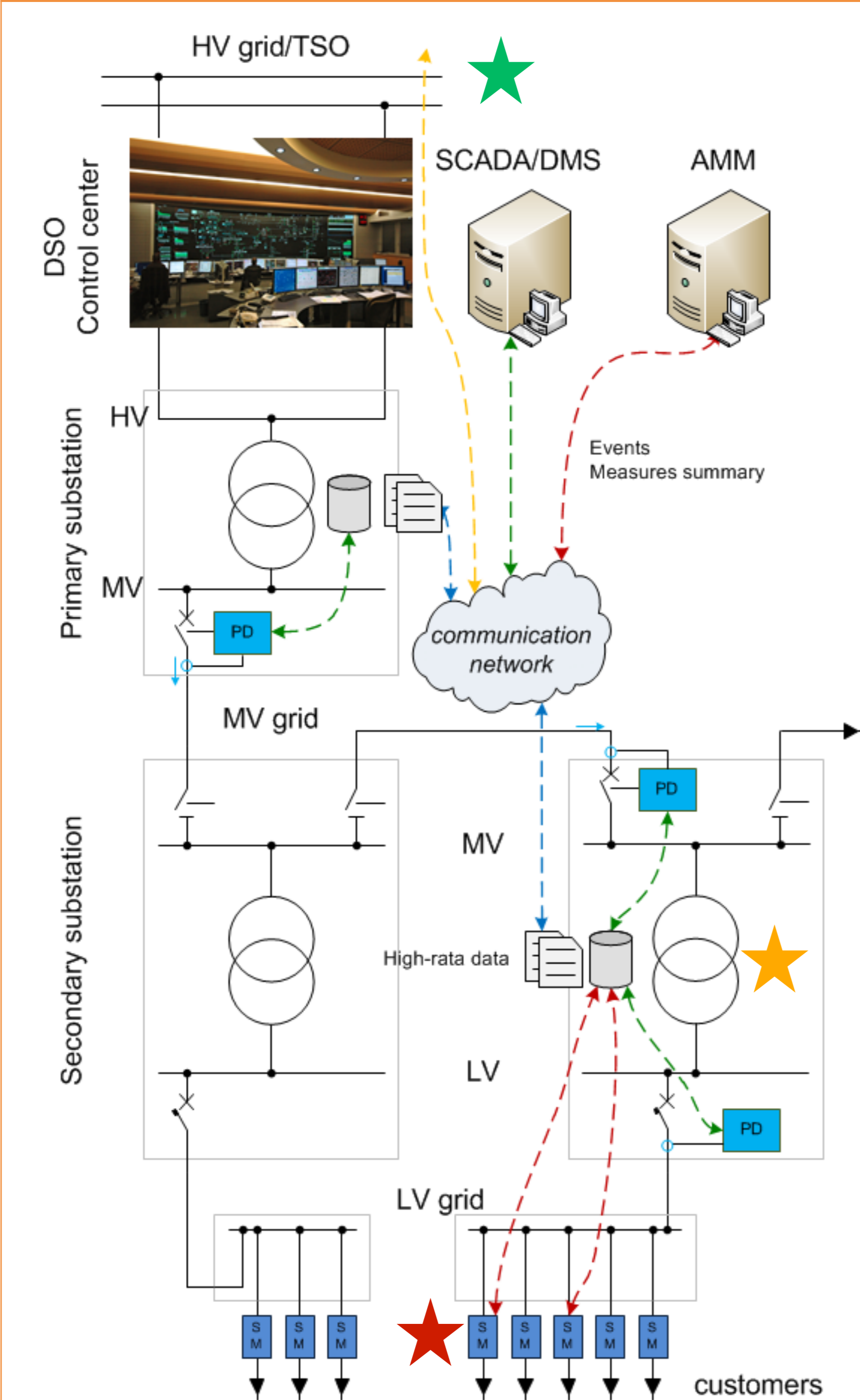

- Hierarchical (integration)
- Distributed (local data management and analysis, vertical and horizontal integration)
- Standard-based (IEC 61850, CIM and DLMS/COSEM) information exchange

Congestion management

- Hierarchical control system:
- Primary (IED) for hard real-time control
 - Secondary (SAU) for local optimization
 - Tertiary (DMS) for global optimization

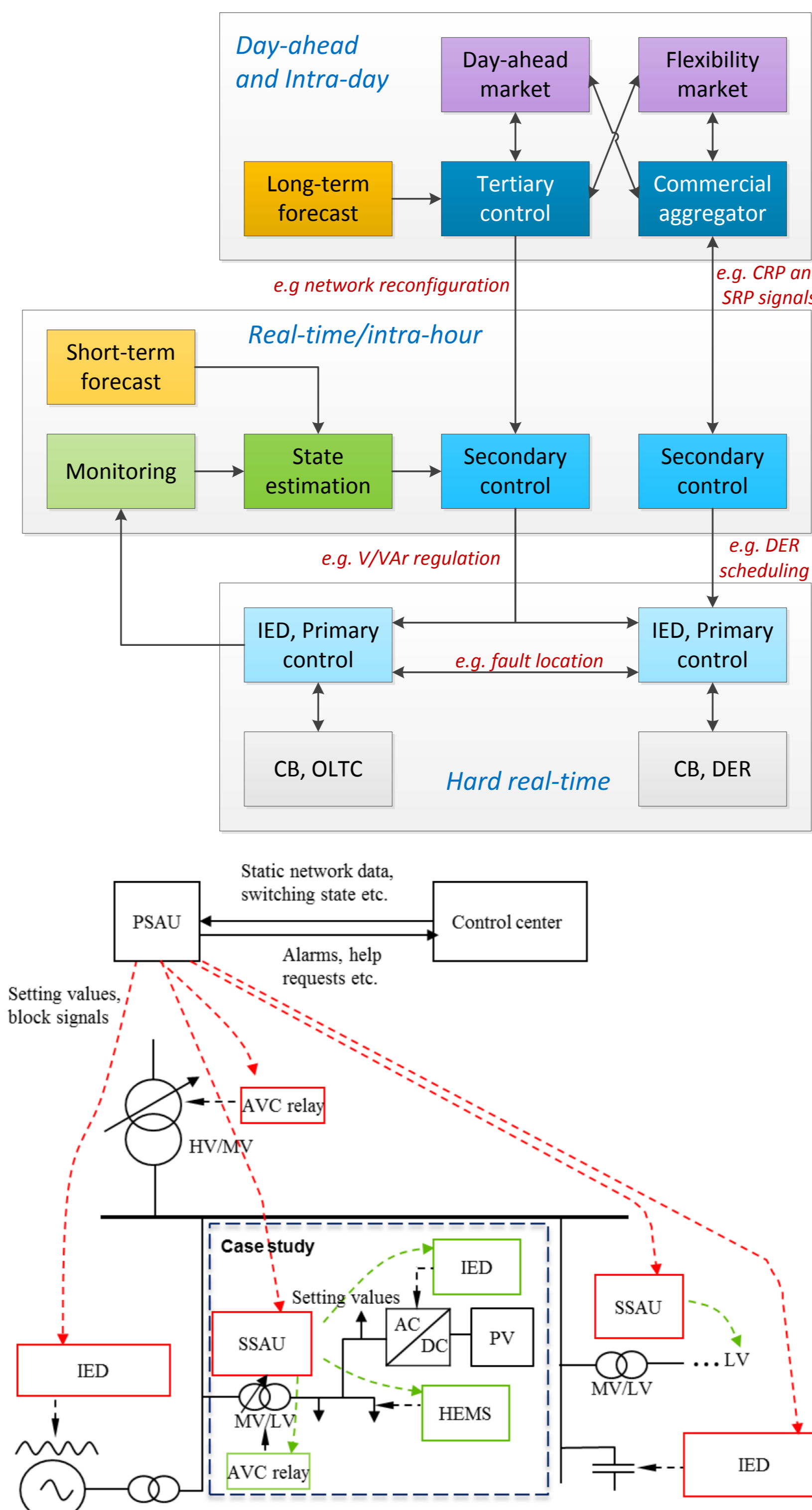

RTDS demonstrations

Hardware and software-in-the-loop testing with commercial IEDs and a prototype Substation Automation Unit

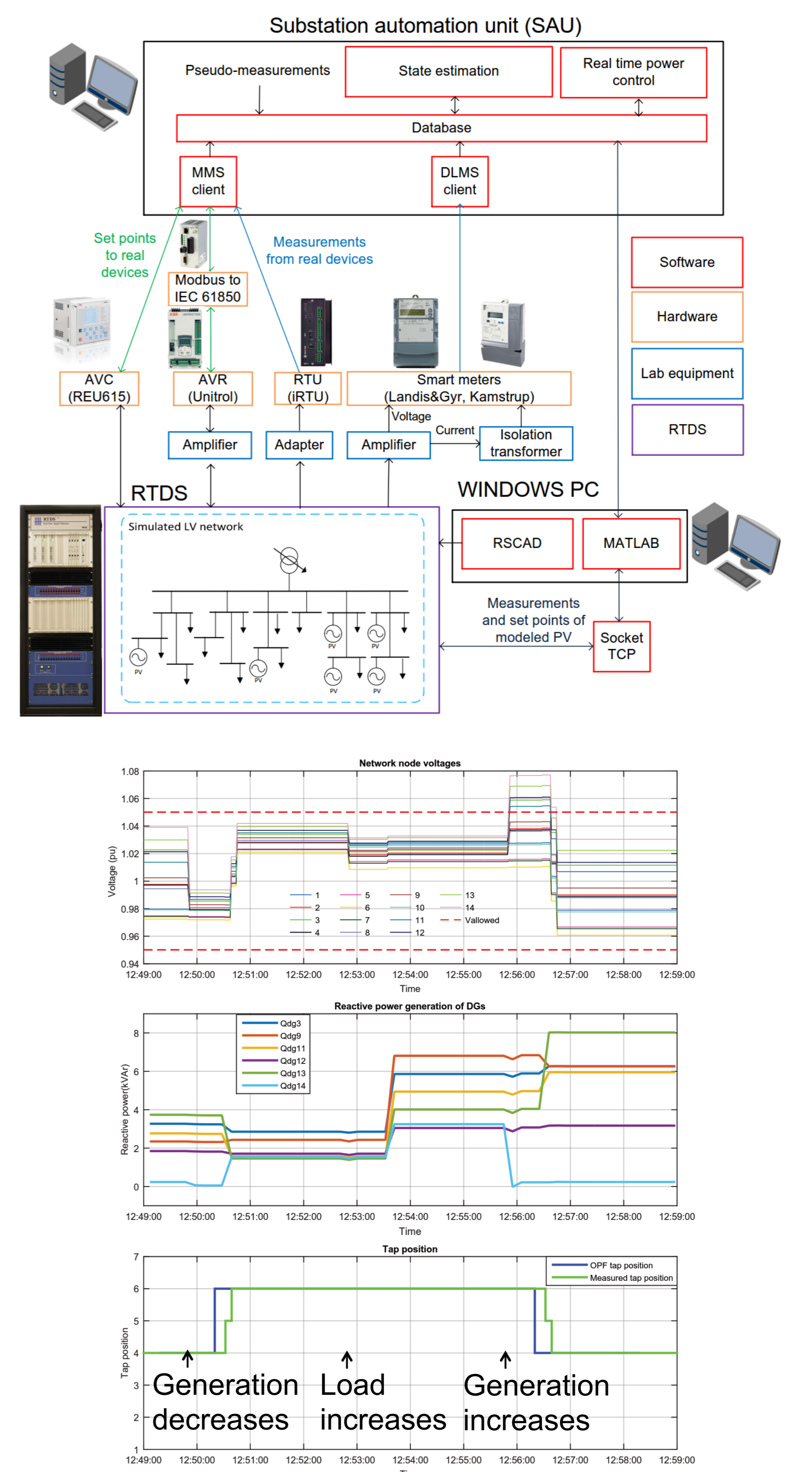

Results so far

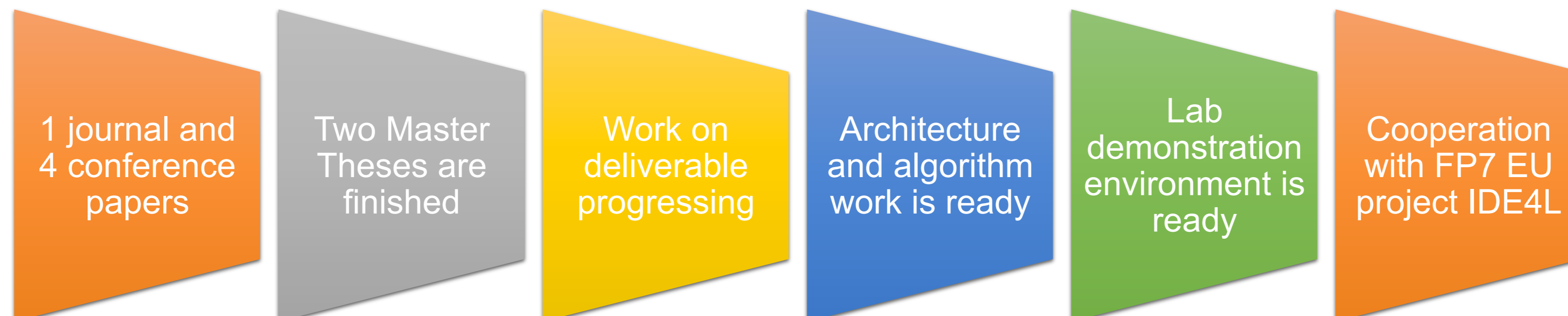

Solution Architect for Global Bioeconomy & Cleantech Opportunities

