

MMEA D4.5.1.1

New applications for bipolar charge measurement system

V1 – March 2014

Contractors

DEKATI Ltd.
Tykkitie 1
FI-36240 Kangasala
Finland
Tel. +358 3 3578100
Fax +358 3 3578140
Email sales@dekati.fi
www.dekati.com

TTY säätö
Aerosolifysiikan laboratorio

Publication data form

1. Programme CLEEN Measurement, Monitoring and Environmental Assessment		2. Contract No SHOK n:o 3155/31/09	
3. Project Title WP 4.5.1		4. Coordinator CLEEN oy	
5. Deliverable Title New applications for bipolar charge measurement system		6. Report No	
7. Deliverable Responsible V. Niemelä, Dekati	8. Language English	9. Publication Date 03/2011	
10. Author(s) V. Niemelä, A. Ukkonen		11. Affiliation Dekati	
12. Summary This document is a summary of findings in aerosol particle bipolar charge measurement research, conducted by Dekati Ltd. in the 4 th funding period of CLEEN MMEA programme. Deliverable discusses about particle charge itself, phenomena and methods related to that and finally presents the most promising applications and markets where commercial business is possible.			
13. Notes			
14. Internet reference			
15. Key Words Charge measurement, aerosol bipolar charge		16. Distribution statement Restricted	
17. No of Pages 12	18. Price, € FOC	19. Declassification date N/A	20. Bibliography N/A

Table of Contents

Publication data form	3
Table of Contents	1
1 Introduction.....	1
2 Importance of electrical charge of particles	1
3 Electrostatic forces	1
4 Charging mechanisms	2
5 Methods for charge measurement.....	4
5.1 Net charge measurement methods.....	4
5.2 Bipolar charge measurement methods	5
6 Application areas for charge measurement.....	7
6.1 Pharmaceutical industry.....	7
6.2 Powder manufacturing, particle and powder transportation processes.....	7
6.3 Combustion and power plants: Electrostatic precipitators and Scrubbers	7
6.4 Nanoparticle research and manufacturing	7
6.5 Electrostatic painting /powder painting / coating	8
6.6 Triboelectrical sensor manufacturers and researchers.....	8
6.7 Printing machines an toners	8
6.8 Air filtration	8
6.9 Powder explosion research.....	8

1 Introduction

Measurement, Monitoring and Environmental Assessment” (MMEA) is one of the research programs of the Cluster for Energy and Environment (CLEEN). A sub-project 4 of this research program is named “Development of on-line monitoring technologies”.

During the 4th funding period (FP4) Dekati focused on utilizing the developed technologies in different applications, putting special emphasis on the developed aerosol particle electrical charge measurement.

This deliverable 4.5.1.1. presents the key findings of this research. It contains basic background of the particle electrical charge (chapters 1-4), information about charge measurement methods (chapter 5) and finally chapter 6 focuses on different applications where charge measurement could be commercial business.

2 Importance of electrical charge of particles

Aerosol particle electrical charge changes the way how particles interact with each other and with different surfaces. Electrical charge can lead to significant particle losses in measurement systems or in particle processes or it can cause unwanted surface contamination or particle agglomeration. Charge can even lead to safety hazards in some processes, causing fire and explosions in extreme situations.

On the other hand it is possible to take advantage of the electrical charge; it can be used for example for intentional surface coating (painting) or more efficient particle filtration, it can tell more about particle source or origin and improve processes.

There are several applications where it is important to know what the particle electrical charge is, what is causing it and how it can be used or prevented. For this purpose the Dekati has developed several technologies for aerosol particle electrical charge measurements.

3 Electrostatic forces

The key mechanism in charged particle behaviour is the electrostatic force that changes the particle motion and interaction. This chapter describes the basic mechanisms of electrostatic forces.

Neutral particles: Electrostatic forces don't affect neutral particle behaviour



Same polarity: particles having the same polarity repel each other, thus preventing coagulation and agglomeration



Opposite polarities: Particles attract each other, increasing coagulation and agglomeration

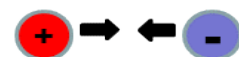

Space charge effect: If the net charge of a particle group is high, repulsive forces between particles become high and particle moves away from each other

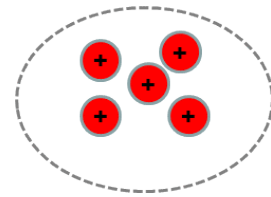

Charged particle near conductive surface creates *mirror charge*. Force between particle and surface makes particle move towards the surface resulting finally in deposition to the surface.

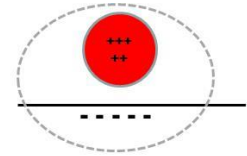

Particles drift in electric field. This can be used for particle collection, but it can also cause unwanted particle losses.

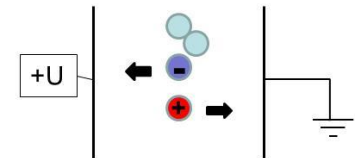

Insulated parts of *transportation lines* collect particles due to diffusion that then get charged. Accumulation of charge creates an electric field that finally prevents charged particles penetration through tube.

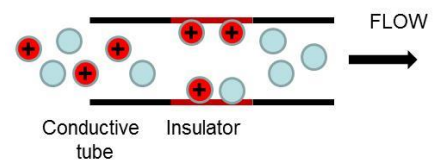

4 Charging mechanisms

There are several different particle charging/neutralization mechanisms that affect particle charge levels. Some of these are intentional mechanisms, some are natural, some can be controlled and some not. Material plays an important role in many of these mechanisms, and by material selection it is possible to understand, control and use charge phenomena.

The following table lists some of the main charging mechanisms, and some of these are explained in more detail in the following pages.

- Natural charge distribution / Equilibrium charge distribution
- Flame charging
- Static electrification
 - o Electrolytic charging
 - o Spray electrification
 - o Contact charging / triboelectrification
 - o Induction charging
- Corona charging
 - o Diffusion charging
 - o Field charging
- UV-charging
- Neutralization
 - o Radioactive Neutralizer
 - o Corona neutralizer
 - o X-ray

4.1.1 Natural (Boltzmann) charge distribution

Ambient air contains about 1000 ions /cm³, and the amount of positive and negative ions is approximately the same. These ions are caused by cosmic radiation and radioactive gases, and over the time they drive the aerosol particles to a certain charge equilibrium called Boltzmann equilibrium charge distribution.

- Neutral particles will acquire charge by collision with ions
- Charged particles will lose charge as those attract oppositely charged ions
- For highly charged particles in air, time to achieve equilibrium can be long (100 min.)

TABLE 15.4 Distribution of Charge on Aerosol Particles at Boltzmann Equilibrium

Particle Diameter (µm)	Average Number of Charges	Percentage of Particles Carrying the Indicated Number of Charges								
		< -3	-3	-2	-1	0	+1	+2	+3	>+3
0.01	0.007				0.3	99.3	0.3			
0.02	0.104				5.2	89.6	5.2			
0.05	0.411			0.6	19.3	60.2	19.3	0.6		
0.1	0.672		0.3	4.4	24.1	42.6	24.1	4.4	0.3	
0.2	1.00	0.3	2.3	9.6	22.6	30.1	22.6	9.6	2.3	0.3
0.5	1.64	4.6	6.8	12.1	17.0	19.0	17.0	12.1	6.8	4.6
1.0	2.34	11.8	8.1	10.7	12.7	13.5	12.7	10.7	8.1	11.8
2.0	3.33	20.1	7.4	8.5	9.3	9.5	9.3	8.5	7.4	20.1
5.0	5.28	29.8	5.4	5.8	6.0	6.0	6.0	5.8	5.4	29.8
10.0	7.47	35.4	4.0	4.2	4.2	4.3	4.2	4.2	4.0	35.4

4.1.2 Flame charging

Flame charging occurs when particles are formed in or pass through a flame

- Direct ionization of gas creates high concentrations of positive and negative ions
- Thermionic emissions of electrons or ions from particles

Net charge acquired by the particles depends on the material, and it is usually symmetric with respect of the polarity. This particle charge (when it differs from Boltzmann equilibrium) can be used to determine particle concentration levels, sources or particle generation processes, and e.g. many newly developed particle sensors rely on this information.

4.1.3 Static electrification

In static electrification particles are charged as they separate from bulk material or surface by mechanical action. Charge caused by this process can be very high, but it is normally not very reproducible. Charge depends on e.g. materials, temperature, humidity, force and other variables.

- In electrolytic charging liquids with high dielectric constant are separated from solid surfaces
- In spray electrification some liquids have charged surface layers due to surface effects. Atomization, bubbling etc. produce charged droplets.

- In Contact charging / triboelectrification dry, nonmetallic particles are separated from solid surfaces or the particles are in contact with each other. Charge is transferred between the particle and the surface
- In induced charging Particle separates from surface in the presence of electric field

4.1.4 Particle chargers

Several different types of particle chargers are available and used in various particle measuring instruments and other applications. The most common are:

- Corona chargers, producing unipolar ions with corona discharge. These are used in e.g. Dekati ELPI™, TSI EAA and NSAM) and other instrumentation, and for example in electrostatic precipitators in power plants and indoor air cleaners.
- UV Chargers where particles are irradiated with ultraviolet light, causing electrons emitted from the particles. This method is efficient for particles smaller than 1 μm , and it is highly sensitive for particle material
- Neutralizers produce high amounts of bipolar ions, equal number of positive and negative ions that are used to neutralize particles. Net charge becomes zero, but the particles obtain equilibrium charge distribution which can be used for measurement in e.g. SMPS systems. Methods are radioactive sources (Polonium-210, Krypton-85 or Americium-241), bipolar corona discharge or X-Rays.

5 Methods for charge measurement

There are several methods for electrical charge measurements:

5.1 Net charge measurement methods

5.1.1 Faraday pail, cup, cage

Measures net charge of particles or net charge/mass ratio. In Faraday Pail Particles are poured inside the pail, charge is measured with electrometer and sample is weighed to get the charge / mass ratio. In Faraday cup particles collected by filter, current is measured and filter is weighed before and after collection

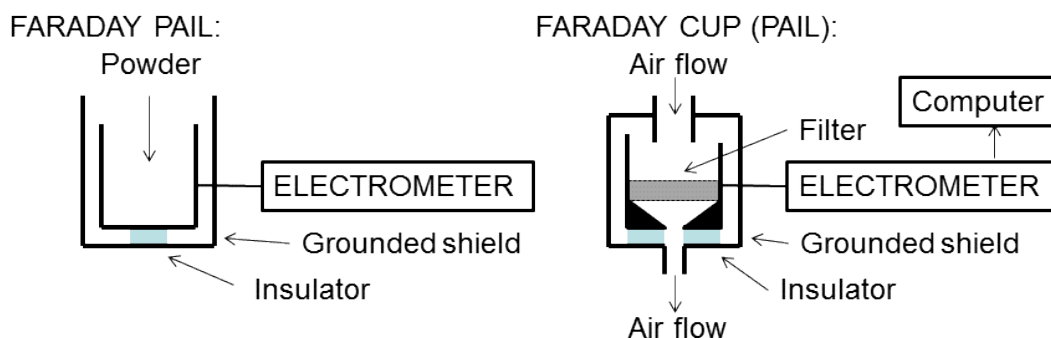

© Dekati Ltd.

5.1.2 Impactor methods

In electrical impactor methods charged particles are collected in single or multistage impactors. This results to a net charge or net charge as a function of sizes. Charge/mass -ratio can be calculated after chemical or gravimetric analysis. Instruments utilizing this technology are for example eNGI (not commercial) and ELPI+™. If particles are charged in a controlled way prior to impactor the system can be used for concentration and size distribution measurement (ELPI™).

5.2 Bipolar charge measurement methods

5.2.1 TDMA

TDMA consist two differential mobility analyzers (DMAs). First is used without charger and classifies particles according electrical mobility. This depends on how many charges particle has. Second unit uses neutralizer and measures the size of particles. This gives bipolar charge distribution (Charge/particle) as a function of size for particles < 200 nm, but not in real time.

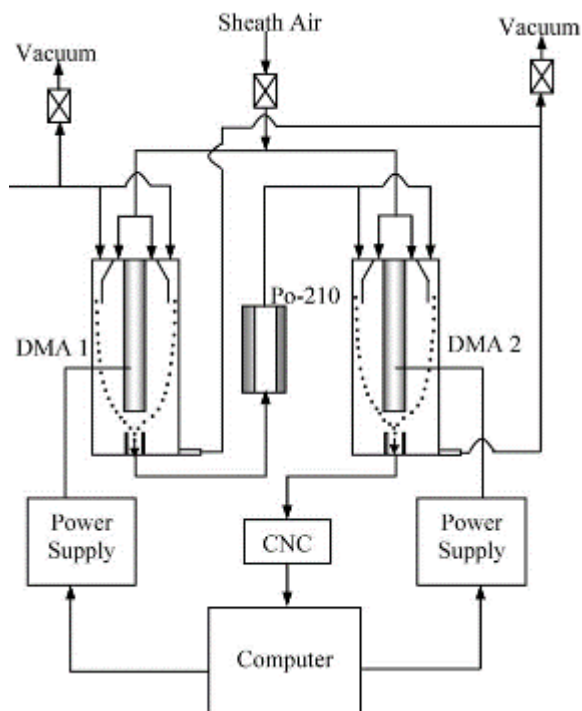

Kim et al. 2005, JCIS

5.2.2 Electrostatic precipitation methods

In electrostatic precipitation particles are collected with electrostatic fields, and floating electrometers are used to measure the collected charge. Charge-to-mass ratio can be determined after particle weighing or chemical analysis.

There are no commercial instruments available but several self-made systems have been built by researchers and universities.

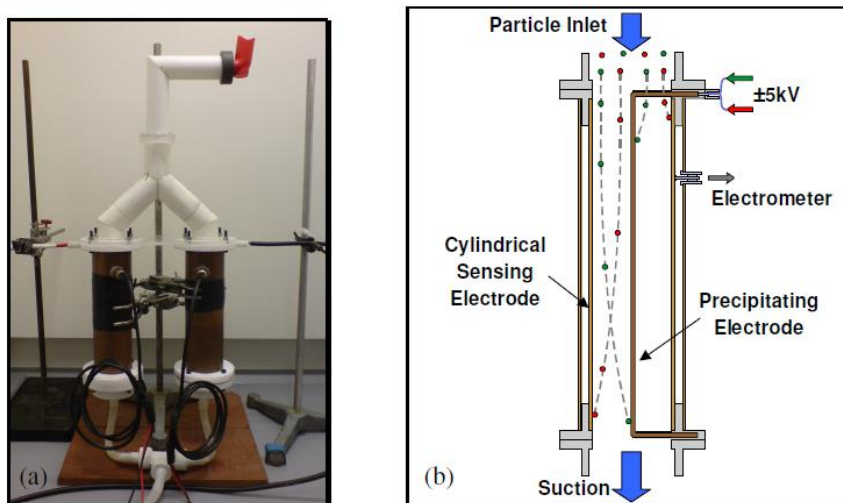

Electrostatic precipitator. O'Leary et. al.: The bipolar nature of charge resident on supposedly unipolar Aerosols. Journal of Physics, Conference Series 142 (2008)

5.2.3 Bipolar Charge Measurement System BOLAR

BOLAR system, developed by Dekati Ltd. in Finland, utilizes electrostatic precipitation in five different size classes, thus enabling size-classified, real-time bipolar charge measurement. Flow divider divides the measured sample to five outlets; each one having a pre-separator impactor after which the particle charges are measured with cylindrical electrostatic precipitators. A backup filter is also used to collect all neutral particles.

5.2.4 ESPART

ESPART instrument, developed by Hosokawa Micron corporation in Japan, is a single particle analyser used for pharmaceutical powder and toner particle charge measurements. Particles are oscillating in an acoustic and/or electric field and the motion is measured of a laser doppler velocimetry or by using image analysis.

6 Application areas for charge measurement

In general control and measurement of the electrical charge is important in all applications where 1) the particles are intentionally generated and used for a certain purpose or 2) when the particles and their properties are measured or 3) when there is a risk for powder fire / explosions. The following chapters describe some of the most important applications where there is a need and / or market for charge measurement technologies.

6.1 Pharmaceutical industry

There is an increasing interest in pharmaceutical industry on particle and powder electrostatic properties and particle charging. Information about particle charge can be used to make inhalable drug devices more stable, producing more constant amount of drugs. It can also influence on drug vs. carrier particle sizes, causing better drug delivery to lungs and better repeatability of the dose.

Also in pill manufacturing processes electrostatic charge can improve the quality of the drug.

6.2 Powder manufacturing, particle and powder transportation processes

This covers all the typical processes where powders are made for any certain purpose. By controlling the charge levels it is possible to separate powders, reduce powder losses and surface contamination, improve powder properties and so on.

6.3 Combustion and power plants: Electrostatic precipitators and Scrubbers

Electrostatic precipitation (ESP) is a key component in power plant flue gas cleaning systems. A corona discharge is used to charge particles to a high electrical charge level, and an electrical field is used to collect charged particles. In order to optimize the charging process it is important to know the relationship between ESP charging power (charging current) and particle collection efficiency. Knowing this enables ESP optimization for maximum benefit (efficiency vs. cost) or just for maximum efficiency. Bipolar charge measurement allows also detection of so called ESP back corona which significantly reduces ESP efficiency.

There are also wet scrubbers where particle charging is used to increase particle collection efficiency.

6.4 Nanoparticle research and manufacturing

Nanoparticle research is an important future application for charge measurements. These particles are intentionally generated for a known purpose, and knowing, controlling and using their electrical charge levels helps using them for their intended purpose.

6.5 Electrostatic painting /powder painting / coating

Charged particles are used to coat surfaces, and knowing the charging properties and particle charge levels it is possible to optimise charging process and reduce the required amount of coating powers, thus reducing the costs.

6.6 Triboelectrical sensor manufacturers and researchers

Triboelectric sensors are commonly used in e.g. power plant flue gas emission measurement systems, and the latest application is in vehicle OBD sensor development. There are several manufacturers whose sensors rely on particle charge; however particle charge levels and their influence on the sensors is somewhat unknown. Research is required to understand how particle charge affects sensor reading, and on the other hand if particles carry a natural charge how this can be used to detect cleaning system malfunctions.

6.7 Printing machines and toners

Printing and copying machines are using charged ink particles in their operation. Information about ink powder electricity is important for the machine operation and optimization.

6.8 Air filtration

It has been long known that particle charge has an effect on particle filtration in different filters. By measuring and controlling the particle charge levels it is possible to increase the efficiency of filters and improve filter testing procedures. An increasing market is currently in China where household air filters are a huge market due to poor outdoor air quality.

6.9 Powder explosion research

Powder explosion can cause fire and explosions if there is a high concentration of dust that. Electrical charges can cause sparking, causing explosions. Measuring the electrical charges can help identifying these risks and