



TAMPEREEN TEKNILLINEN YLIOPISTO
TAMPERE UNIVERSITY OF TECHNOLOGY

ALI UMAIR

**DETECTION ALGORITHM FOR THE CROSS COUNTRY EARTH
FAULTS IN MEDIUM VOLTAGE NETWORK**

Masters of Science Thesis

Examiner: Professor Pertti Järventausta and Dr Tech. Ari Nikander
Examiner and topic approved in the
Faculty of Computing and Electrical
Engineering council meeting on 4
June 2014.

ABSTRACT

TAMPERE UNIVERSITY OF TECHNOLOGY

Master's Degree Program in Electrical Engineering

UMAIR, ALI: Detection algorithm for the cross country earth faults on medium voltage network

Master of Science Thesis, 85 pages, 1 Appendix pages

December 2014

Major: Smart Grids

Examiner: Professor Pertti Järventausta, Dr. Tech. Ari Nikander

Keywords: Cross country earth faults, double phase faults, distribution automation

The protection of electricity distribution network has been the important topic in terms of reliable and safe power supply for the customers. The field of distribution automation deals with the protection and safety of the electricity distribution network. Recently the topic of centralized protection system has become a hot topic for research and many companies, who are dealing with protection relays, have been working on centralized protection architectures. Traditional protection relays (intelligent electronic device, IED) have the protection blocks for the faults classified as single phase to earth fault, short circuit faults but it is lacking the ability to detect the type of the earth faults termed as cross country earth faults. In cross country earth faults two different phases of the same or different feeder are experiencing the earth fault at different position along the feeder. When the phases are earthed then they are short circuited through the ground. The objective of this thesis is to develop an algorithm to detect the cross country fault using the available protection tools so that the algorithm can be implemented in centralized protection without the need of any new measuring device.

The thesis is divided into two parts. In the literature study part, different types of faults of medium voltage network (e.g. single phase to earth fault, double phase short circuit fault, phase to phase to earth fault and cross country fault), have been discussed along with some of protection techniques for these faults. The details about the IEC61850 standard, the research prototype of centralized protection system of ABB and its protection blocks are also the part of the literature study. The medium voltage network can have neutral isolated or compensated but for this thesis neutral isolated network was the main focus for the research. In the research part, basics of the algorithm for the detection of the cross country fault are explained with the help of the flow charts. The algorithm was tested by different fault scenarios in the PSCAD simulation environment in which three medium voltage (MV) overhead feeders were modelled and also in the real time digital simulator (RTDS) in which two feeders were overhead MV lines while one feeder was MV cable feeder. In each test case, the fault resistances were varied and behavior of the algorithm was observed.

The observations obtained from the testing of algorithm through simulations have proved that algorithm is able to detect the cross country fault and separate the cross country fault from other types of double phase faults. The algorithm is using the protection block signal (i.e. directional earth fault protection block of the IED) for getting triggered. The practical issues relating to its implementation in centralized protection system are highlighted at the end of the thesis. Moreover the algorithm has reduced the time of operation against the cross country fault as compared to the directional earth fault protection block of IED. It was also observed that there are some cases when the fault resistances and the distance between the faults are small then the algorithm detect the cross country fault as the phase to phase to earth fault. For future there is still space for the improvement of the algorithm especially in the cases where the fault is wrongly detected. In addition the algorithm for the compensated neutral network still needs to be developed for the detection of cross country faults.

In the nut shell, it can be said that the new developed algorithm for the detection of the cross country fault covers almost all the cases and it does not need any new measuring device for working. It is also using the protection block of IEDs of ABB so it is easy to implement it in centralized protection system as IEDs are basic blocks for this kind of system.

PREFACE

This thesis was written at the department of electrical energy engineering in Tampere University of Technology by funding from Smart Grids and Electricity Markets (SGEM) project. The simulation studies of this thesis were done in cooperation with the ABB Corporation which is project partner in the SGEM project.

This thesis was supervised by the professor Pertti Järventausta and Dr Tech. Ari Nikander. I want to thank Professor Pertti Järventausta for giving me the opportunity to work on this interesting topic and for reviewing, special guidance and patience during the working period of the thesis. I also want to give special thanks to Ari Nikander, without whom I could not able to understand the background of the problem. His valuable knowledge and research work helped me a lot in solving the problems. I also want to thank to Ontrei Raipala, who provided me the knowledge of the RTDS and helped me in solving the issues related to RTDS simulations. I also want to thank Jani Valtari and Erkka Kettunen from ABB for their technical support and research work. I would also like to thank all my friends and colleagues from the department of electrical energy engineering for the motivational and friendly work atmosphere.

Finally I would like to give special thanks to my parents for the valuable support throughout my studies.

Tampere,
December 9th, 2014

Ali Umair

CONTENTS

1.	Introduction.....	5
1.1.	Objective and content of thesis	5
2.	Distribution network and fault types.....	7
2.1.	Finnish distribution network characteristics	7
2.2.	Isolated and compensated networks in Finland.....	9
2.3.	Fault types in MV network	9
2.3.1.	Single phase earth fault in isolated network.....	9
2.3.2.	Single phase earth fault in compensated network.....	11
2.3.3.	Short circuit and phase to phase to earth faults	13
2.3.4.	Cross country earth fault	14
2.4.	Protection from faults in MV network.....	16
2.4.1.	Directional earth fault protection.....	16
2.4.2.	High impedance earth fault indication	17
2.4.3.	Short circuit fault protection.....	17
2.4.4.	Cross country earth fault protection.....	17
3.	Centralized substation automation system	19
3.1.	IEC 61850 standard	20
3.1.1.	Communication architecture in centralized protection and control systems.....	23
3.2.	ABB's centralized protection and control research project	25
3.2.1.	Overcurrent protection tool	25
3.2.2.	Earth fault protection tool.....	27
3.3.	Traditional protection against cross country faults.....	27
4.	Simulation environment	28
4.1.	Introduction to PSCAD and Matlab	28
4.2.	Model of isolated MV network in PSCAD	29
4.3.	Introduction to RTDS and RSCAD	30
4.4.	Model of isolated MV network in RSCAD	31
5.	Algorithm for cross country fault detection	33
5.1.	Flow chart of algorithm	33
5.2.	Background of algorithm	34
5.3.	Phase currents.....	35
5.4.	Basics of method	36
5.5.	Explanation of algorithm	40
5.6.	Limits and methods to find limits.....	43
6.	Simulations and results from PSCAD.....	47
6.1.	Test cases	47
6.2.	Results and discussions.....	48
6.2.1.	Single phase earth fault on one feeder only	48

6.2.2.	Phase to phase to earth fault on one feeder only	49
6.2.3.	Double phase short circuit fault on one feeder only	51
6.2.4.	Double phase short circuit fault and phase to phase to earth fault on two feeders simultaneously	53
6.2.5.	Single phase fault on two feeder separately in different phases at same time	55
6.2.6.	Phase to phase to earth fault and single phase earth fault on two separate feeders simultaneously	57
6.2.7.	Discussions	59
7.	Simulations and results from RTDS	61
7.1.	Results and observations	61
7.1.1.	Single phase earth fault on one feeder only	61
7.1.2.	Phase to phase to earth fault on one feeder only	63
7.1.3.	Double phase short circuit fault on one feeder only	65
7.1.4.	Double phase short circuit fault and phase to phase to earth fault on two feeders separately	67
7.1.5.	Single phase fault on two feeder separately in different phases at same time	69
7.1.6.	Phase to phase to earth fault and single phase earth fault on two separate feeders simultaneously	71
7.1.7.	Cross country fault on same feeder	73
7.1.8.	Observations	75
8.	Implementation possibilities of developed method in centralized protection and control systems	77
8.1.	Proposed changes in DEFPTOC of IED	77
8.2.	Proposed timing operation	77
8.3.	Some practical implementation issues	78
9.	Conclusion	80
9.1.	Main results	80
9.2.	Recommendations for future work	81
	References	82
	Appendix A: The three feeder MV network model in PSCAD	86

LIST OF ABBREVIATIONS

ACSI	Abstract communication service interface
A/D	Analogue to digital conversion
BLKOPER	Block operation (signal)
BLKST	Block start (signal)
CDC	Common data classes
CLK	Clock frequency
DEPTOC	Directional Earth fault protection
DER	Distributed energy resources
DSO	Distribution system operators
DT	Definite time
EMTDC	Electromagnetic transients including DC
EMTP	Electromagnetic transients program
FRTIMER	Freeze timer (signal)
GOOSE	Generic object oriented substation event
GSE	Generic substation event
GSSE	Generic substation state event
IDMT	Inverse definite minimum time
IED	Intelligent Electronic Device
LN	Logical Node
LV	Low Voltage
MU	Measuring unit
MV	Medium voltage
RTDS	Real time digital simulator
SCSM	Specific communication service mapping
SGCB	Specific group configuration block

LIST OF SYMBOLS

ω	Angular frequency
C_0	Zero sequence capacitance usually equal to phase to earth capacitance
E	Phase voltage before fault
E_{L1}	Phase voltage of Line 1 (phase A)
I_0	Zero sequence current
I_A	Current of phase A
I_B	Current of phase B
I_C	Current of phase C
I_e	Earth fault current without fault resistance
I_{ef}	Earth fault current with some fault resistance
$I_A + I_B$	Sum of phase current phase A and B
$I_B + I_C$	Sum of phase current phase B and C
$I_A + I_C$	Sum of phase current phase A and C
R_0	Zero sequence resistance also known as leakage resistance
R_f	Fault resistance
R_L	Resistance connected parallel to the compensated coils
Z_0	Zero sequence impedance
Z_1	Positive sequence impedance
Z_2	Negative sequence impedance

1. Introduction

Distribution automation plays an important role in the protection of the electricity distribution network from the different type of faults. However there is always space for the improvements in this field. The main aim of the protection of the network from faults is to safe human beings, properties and avoids long service breaks. This in return will reduce the outage duration and outage costs. Nowadays, customers want the continuous supply of power for their business and home without any interruptions. The demand for continuous power supply has forced electricity distribution companies to improve the quality of the supply. Due to which the maintenance cost is increased. Thus still there is need for the development of techniques which will reduce the fault frequency and enable more efficient protective methods in order to avoid long outage durations and damages done by the faults in the distribution network.

In Finland over 80% of the annual outage costs of customers are due to faults in public medium voltage (MV) distribution networks. Out of these faults most of outage cost is due to the permanent faults. It is estimated that about over 90% faults are temporary which can be cleared by auto-reclosing and below 10 % are permanent. Among permanent faults about 50% are earth faults. Many techniques have been developed in order to detect the earth fault even the high resistance earth faults.

In medium voltage network, the steady state behavior of the protection system along with its dynamic behavior is influenced by the way how the neutral of the distribution system is earthed. Distribution system operators (DSO), working in Finland, have long experience of operating the 20 kV system with the isolated neutral or as compensated system. The resistivity of earth in Finland is very high which can lead to small earth fault currents in isolated systems but there are some type of earth faults where the fault current can even be more than usual earth fault and act as like short circuit faults. These types of earth faults are usually termed as cross country earth faults.

1.1. Objectives and content of thesis

This thesis focuses on the method development to detect the cross country earth faults and to separate these faults from other types of the faults in medium voltage network. The main idea of the developed method is based on the change in the phase currents and all combinations of sum of two phase currents. The method detects the cross country faults and protects the distribution network from them.

Medium voltage network consisting of three feeders was modeled in simulator. The model was used for the method development and for the testing purpose. The method uses the triggering signal from the directional earth fault protection function. After that faulty feeders and faulty phases are determined by calculating the change in combinations of sum of two phase currents and phase currents on each feeder respectively. The

measured combinations of sum of two phase currents are tested for defined limits to separate the cross country faults from the other type of faults. This method is designed to implement in the systems based on the concept of centralized protection and control.

Chapter 2 discusses the theory of the faults in medium voltage network in Finland and their protection methods. Chapter 3 explains the modern central protection system and role of IEC 61850 standard. Moreover this chapter also throws light on the ongoing research project of centralized protection system of ABB and some of its protection functionalities used in medium voltage network and implemented its IEDs. Chapter 4 is written in order to give the idea of the simulation environment before going into details of the developed method. The novel developed method for detecting the cross country earth fault is explained in detail in chapter 5. This chapter includes the description of the flow chart and basics of method along with the explanation of the method with an example. Chapters 6 and 7 show the results of the simulation environment as described in chapter 4 in different fault scenarios. Chapter 8 discusses the future aspects of the method and its implementation in real medium voltage networks. In the end chapter 9 concludes the thesis along with the observation and success of the method.

2. Distribution network and fault types

Distribution network is the back bone in the power transmission of any country. The power is generated by power plants and reached to the customers through the transmission and distribution network. In order to supply reliable and cheap power to the customers, it is necessary to protect the network from the faults. The faults can be of different types e.g. short circuit or earth faults etc.

This thesis is dealing with the protection of the network from the cross country earth faults in the medium voltage (MV) network. Cross country faults are type of earth faults in which faulty phases are short circuited faults through the ground. That's why a method is needed to detect these faults and protect the network from the short circuit currents. In cross country earth faults the short circuit between the phases on same or different feeders occur through the ground. Before going into details of the cross country faults, it is necessary to have a look on the structure of the distribution network and the parts of the networks where cross country faults can occur. This chapter of thesis is focused on the structure of distribution network in Finland, type of faults in medium voltage network and existing methods to safe the network from cross country faults, to detect them and separate them from the other faults.

2.1. Finnish distribution network characteristics

Electricity distribution system is different in different countries. The structure of the main distribution network in the country depends upon the requirements of the country, sources for generation and geographical territories in that country. For example in Finland, loads currents are separated from the neutral and returning currents through the earth due to high ground resistance. In this method power is supplied to the loads between the phases (i.e. positive and negative sequence parameters provide the information of the power supplied to loads). The zero sequence parameter is used for the earth fault detection. The technique of detection of fault by zero sequence parameters is used in high voltage and medium voltage network. In low voltage (LV) network has four wire systems and the neutral point is earthed. One advantage of earthed four wire system is that MV network is not affected if there is an earth fault in the LV network. [4] [2]

In Finland three levels of voltages are used in the distribution networks. These voltage levels are 110 kV, 20 kV and 400 V for the high voltage, medium voltage and low voltage networks respectively. [13] The main features of distributing network of Finland are as follows [3]:

- Primary substations (main substation or feeding substation) normally provides with one or more 110/20 kV transformers fed by power transmission network
- Medium voltage (20 kV, sometimes 10 kV) feeders

- Switching substations along some feeders having only circuit breakers
- Distribution substations equipped with a 20/0.4 kV transformer
- A low voltage network with 400 V voltage level
- Network can be isolated neutral or compensated neutral

Voltage level 400 kV is used, as Extensive High Voltage (EHV), for the long distance power transmission in Finland from generation sources to the primary substations. Figure 2.1 shows the basic structure of the transmission and distribution network in Finland. [4]

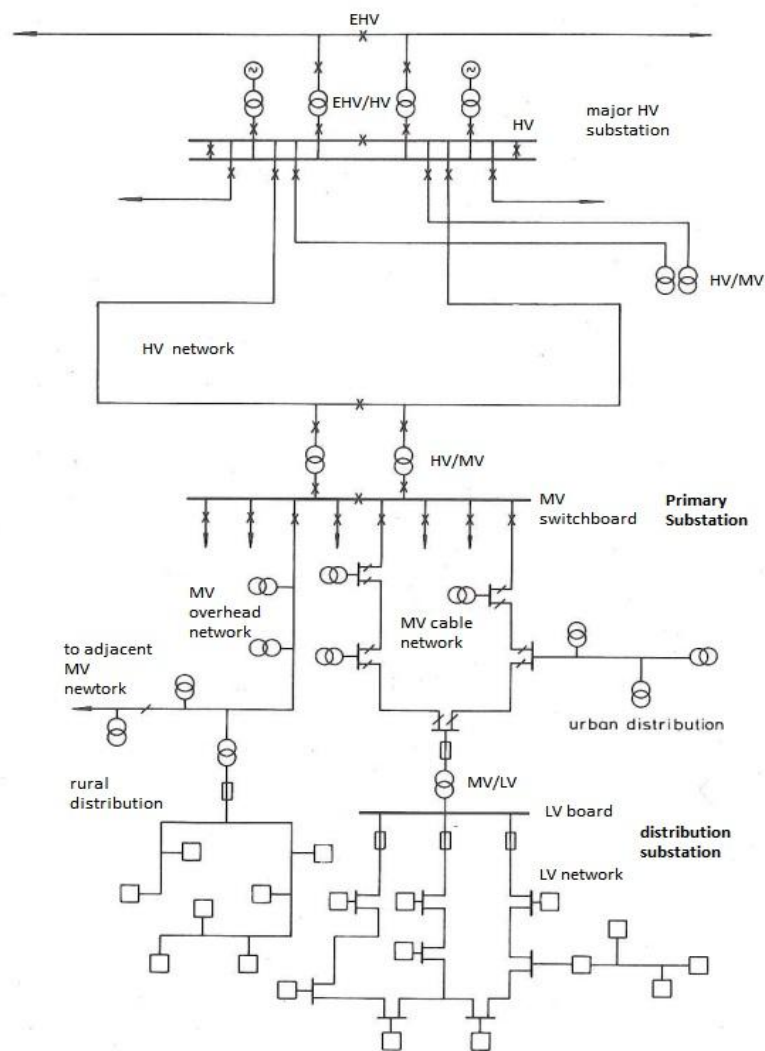

Figure 1.6 EHV/HV/MV/LV network arrangements

Ⓢ Generator X Circuit breaker → Feeder □ Customer
 ⊙ Transformer / Disconnecter ⇨ Fuse

Figure 2.1 Basic structure of transmission and distribution systems in Finland. [5]

As there is no neutral wire in the MV voltage networks, therefore these networks are divided into isolated neutral network or compensated neutral network categories. These categories are explained in the next section.

2.2. Isolated and compensated networks in Finland

As said in the earlier section, the medium voltage network has the three wire system. This means that there is no neutral/earth wire. In medium voltage network the primary substation transformer can be in delta configuration or in the star configuration. In delta configuration there is no neutral point so there is no need for the neutral connection to the earth. Sometimes in delta configuration the primary transformer is forced to make a neutral point through an earthing transformer. In the case of star configuration we have the neutral point automatically. The importance of neutral point can be seen in the case of the earth faults. In the power systems, different ways of neutral treatments have been developed for the protection of the system from the over voltages, the need to restrict the touch potentials etc. depending upon the voltage levels. [6] The neutral treatment is classified generally as isolated neutral or the compensated neutral hence networks are called as isolated network and compensated network respectively. In isolated network the neutral point is left as it is while in compensated network the neutral point is earthed via an arc-suppression coil known as the Petersen coil. This coil lowers capacitive earth fault current and also avoid over voltages in network [5].

In Finland nearly 50% of the medium distribution networks are isolated. The compensation in the medium voltage network can also be done by the implementation of several compensated coils along the distribution network depending upon the earth fault current (i.e. decentralized compensation). [7] Due to different behaviors of the fault currents in isolated and compensated network, there is need of different methods for the fault detections. In the next section some background of the single phase earth faults has been explained for the isolated and compensated systems.

2.3. Faults types in MV network

2.3.1. Single phase earth fault in isolated network

In the isolated network, the currents of the single phase to ground faults depend mostly on the phase to earth capacitances of the transmission line. In the event of the fault, the capacitance of the faulted phase is by passed as a result system become unsymmetrical. Then the fault current is composed of the capacitive currents of the healthy phases [6]. The phenomena of single phase to ground fault is shown in figure 2.2.

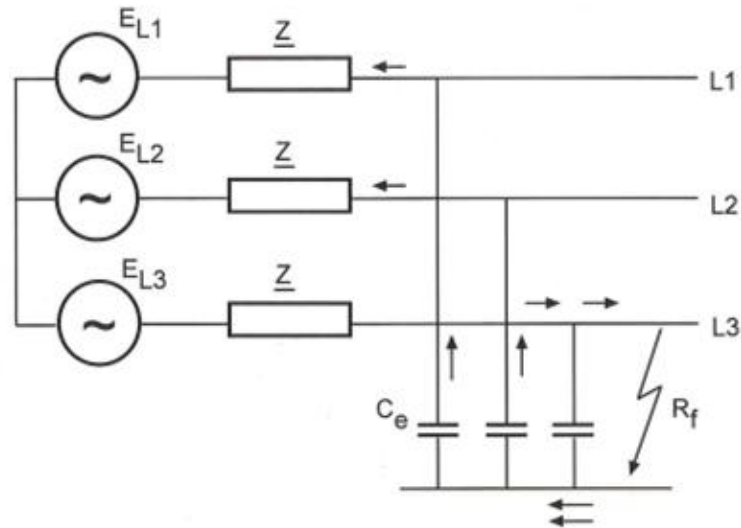

Figure 2.2 Single phase to ground fault with an isolated neutral. [6]

The impedances of the network except the capacitive earth impedances are very small so they can be neglected. The phase to earth capacitance is denoted as C_e . The thevenin's equivalent model of the isolated network in the case of the earth fault is shown in figure 2.3

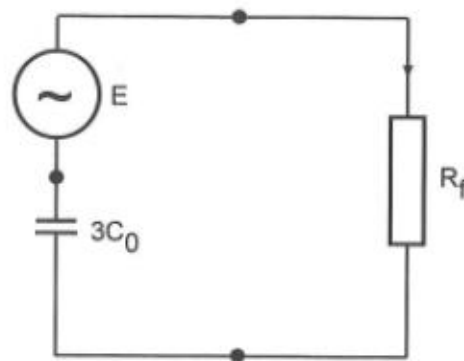

Figure 2.3. Thevenin equivalent circuit in case of single phase to ground fault in the isolated neutral network. [6]

In the case of when $R_f = 0$, the fault current can be calculated by equation 2.1 [6]:

$$I_e = 3\omega C_e E \quad (2.1)$$

Where $\omega = 2\pi f$ is the angular frequency of the network. While in the case when there is some fault resistance, the fault current can be found through equation 2.2. [6]

$$I_{ef} = \frac{I_e}{\sqrt{1 + \left(\frac{I_e R_f}{E}\right)^2}} \quad (2.2)$$

Where I_e is obtained from above equation 2.1. It is also observed that when the single phase to ground fault occurs the voltage levels in the healthy phases increases. Due to this overvoltage phenomenon the chances of the cross country earth fault increases. The voltages in the healthy phases increases according the vector diagram of the voltages which is shown figure 2.4. [6]

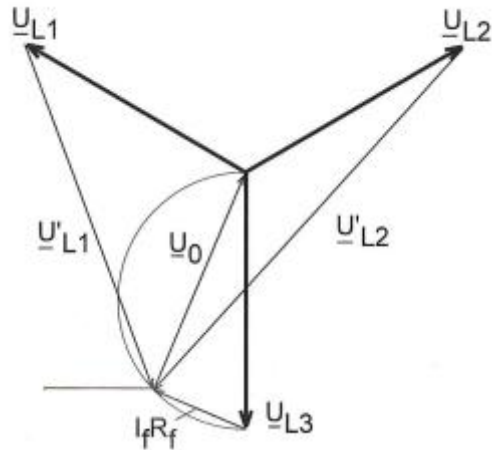

Figure 2.4. Voltage vectors during the single phase to ground fault in isolated neutral network. [6]

2.3.2. Single phase earth fault in compensated network

The compensated systems are also known as the resonant earthing system. In this type of network the capacitance current is compensated by the inductive current provided by the compensated coil. The circuit is parallel resonance circuit and in the case of full compensation only the resistive part of the fault current is left. The resistive current is due to the resistance of the coil and the resistive part of the distribution lines together with the system leakage resistance (R_o). In order to make the selective relay protection to be implemented there is need of specific amount of the fault current. Therefore sometimes parallel resistance R_L is used to increase the fault current. The compensated network looks like in figure 2.5 in case of single phase earth fault as below. [6]

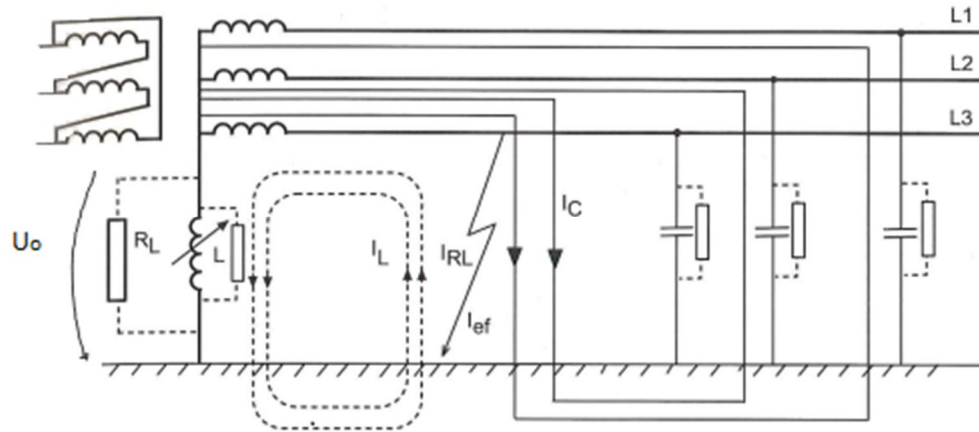

Figure 2.5 Single phase to ground fault with an compensated neutral. [6]

The thevenin equivalent circuit for the phenomena of the single phase to ground fault in the compensated network is shown in figure 2.6. [6]

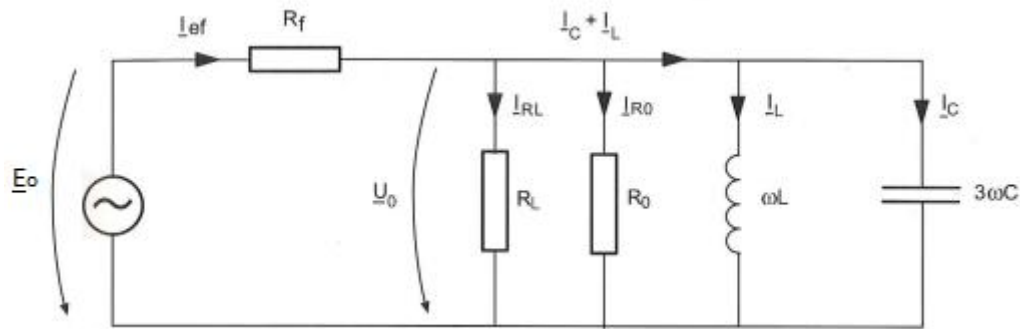

Figure 2.6 Thevenin equivalent circuit in case of single phase to ground fault in the compensated neutral network. [6]

Using the equivalent Thevenin circuit we can write the fault current equation 2.3. [6]

$$I_{ef} = \frac{E \sqrt{1 + R_0^2 \left(3\omega C_0 - \frac{1}{\omega L}\right)^2}}{\sqrt{(R_f + R_0)^2 + R_f^2 R_0^2 \left(3\omega C_0 - \frac{1}{\omega L}\right)^2}} \quad (2.3)$$

In case of exact compensation the equation 2.3 can be reduced to $I_{ef} = \frac{E}{R_0 + R_f}$. In compensated systems the phase to earth voltages of the two healthy phases behaves similar to isolated system. Compensation reduces the fault current provided by the capacitive discharging

2.3.3. Short circuit and phase to phase to earth faults

The short circuit faults are the most common type of faults. These faults are divided into the two phase short circuit fault and three phase short circuit fault. In short circuit faults, phases touch each other directly or through some fault resistance due to which the heavy current flows through the breakers and when these inrush currents are higher than the specified limits the breakers are opened and hence save the network from being collapsed.

The behavior of short circuit fault changes when one of the short circuited phases also experiences the earth fault. This type of fault is known as the phase to phase to earth fault or double phase earth fault. Usually the reason for this type of fault is that when there is the single phase earth fault the voltage of the healthy phases rises. The rise in the voltages leads to the flashover or break down between the earth fault phase and the one of the healthy phase. Phase to phase to earth fault can be shown in figure 2.7 along with their equivalent symmetrical components model. [6]

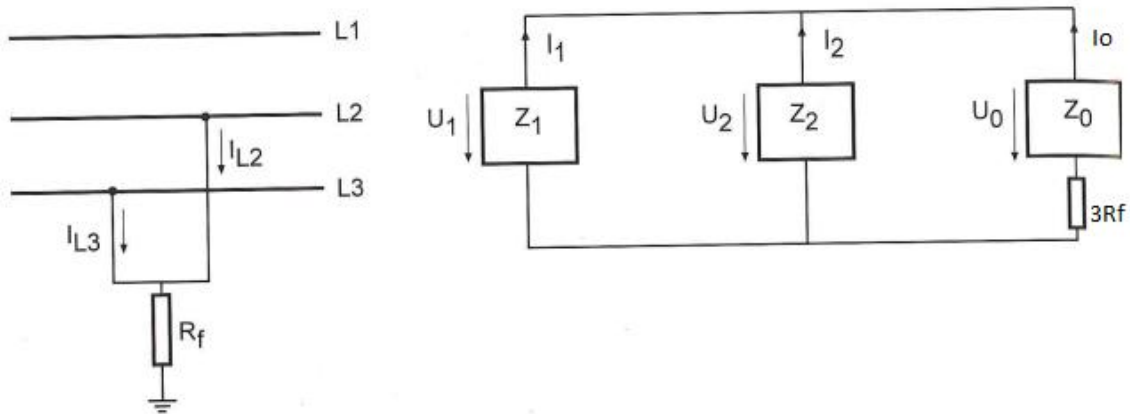

Fig 2.7 The phase to phase to earth fault and corresponding connection of symmetrical component sequence networks. [6]

The currents flowing in different phases can be found by the equations below

$$I_{L1} = -E_{L1} * j\omega C_e \quad (2.4)$$

$$I_{L2} = -j\sqrt{3}E_{L1} \left(\frac{Z_0 + 3R_f - aZ_2}{Z_1 Z_2 + (Z_1 + Z_2)(Z_0 + 3R_f)} \right) - E_{L1} * j\omega C_e \quad (2.5)$$

$$I_{L3} = +j\sqrt{3}E_{L1} \left(\frac{Z_0 + 3R_f - aZ_2}{Z_1 Z_2 + (Z_1 + Z_2)(Z_0 + 3R_f)} \right) - E_{L1} * j\omega C_e \quad (2.6)$$

In equation 2.4 C_e is capacitance of phase conductor to ground while in equations 2.5 and 2.6 Z_0 , Z_1 and Z_2 are zero, positive and negative sequence impedances respectively. The line currents are composed of the capacitive current along with load currents because the system is isolated neutral. The figure 2.7 shows the flow of the capacitive currents as case of phase to earth fault. The equations 2.4, 2.5 and 2.6 will be

used to find the limits values which are used in the algorithm developed in the thesis. The information about the limits and the method to find them is explained in chapter 5.

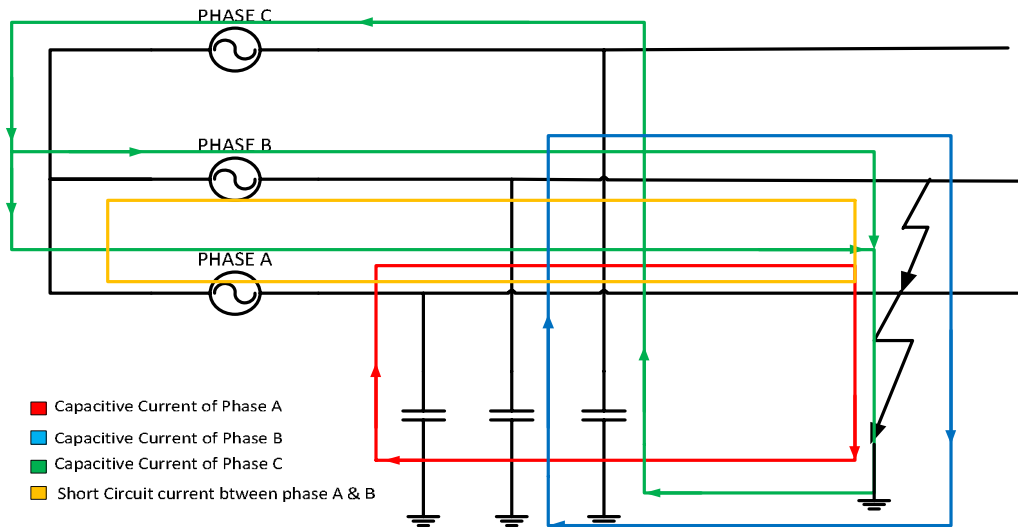

Figure 2.8 Flow of capacitive currents along with short circuit current in case of phase to phase to earth fault between the phase A and phase B.

In figure 2.8 the phases A and B are under the phase to phase to earth fault. In this fault the location of the short circuit and phase to earth fault is same. Due to this the capacitive current due to the discharge of phase A and B conductors' capacitances is same or different in case of fault resistance while the capacitive current from phase C conductors will distribute in phase A and B conductors according to the resistance of the short circuit between phase A and B and the earth fault resistance. In this way the phase A conductor will have current consisting of capacitive current from phase A, B, C and the short circuit current but the capacitive current of phase B entering to phase A conductor and the phase B capacitive current coming through the source side adds to zero current. Same is case for conductor of phase B. In this way only the capacitive current of phase C conductor will occur in phase A and B conductors along with short circuit current.

2.3.4. Cross country earth fault

Cross country faults are type of two phases to earth faults. In this type of fault the both the phase experience a phase to ground fault separately and the phases are short circuited through the ground. In Finland, mostly medium voltage networks are installed in radial topology. In the case of a short circuit in cross country fault, short circuit current may be smaller than the predefined limit of overcurrent protection relay due to ground resistance. Hence they are not easy to detect. While in case of the directional current relays the currents and their angles will exist out of the operation region of relay.

Due to which the faults are not detected. The cross country fault is divided into two categories.

- Cross country fault on the same feeder
- Cross country fault on different feeders

In cross country fault on the same feeder, two separate phases are experiencing the phase to ground fault independently and the location of the faults are different along the same feeder. In this way the two phases are short circuited through the ground and there is earth resistance along with fault resistances between two phases which are short circuited. This type of fault is shown in the figure 2.9. [6]

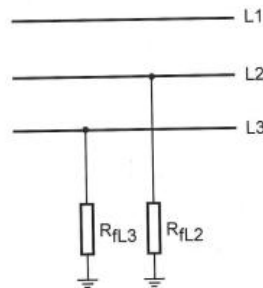

Figure 2.9 Cross country fault on same feeder. [6]

One of the reason for the occurrence of this type of fault is that when the one phase experiences the phase to ground fault then due to the phenomena of the over voltages on the healthy phases increases the chances of the other phase to undergone the earth fault.

In cross country earth fault on different feeders, two separate phases on separate feeders have undergone the phase to ground fault. Again the phenomenon of short circuit between the faulty phases occurs through the ground. It must be noted that phases must be different for the cross country fault on different feeders. If the phases are same then they will be detected by the directional earth fault protection relays and hence the network can be protected. The cross country fault on different feeders is shown in figure 2.10. [6]

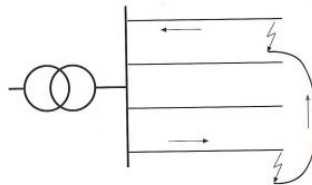

Figure 2.10 Cross country fault on different feeder. [6]

The common reason for this type of fault is that if the earth fault occurs then the over voltages increase the chance of phase to ground fault in the healthy phases on the other feeders of same primary substation. The figure 2.10 shows the flow of capacitive currents due to the discharge of the capacitances of the conductors of the phases along

with the short circuit current between phase A and phase B through the ground.

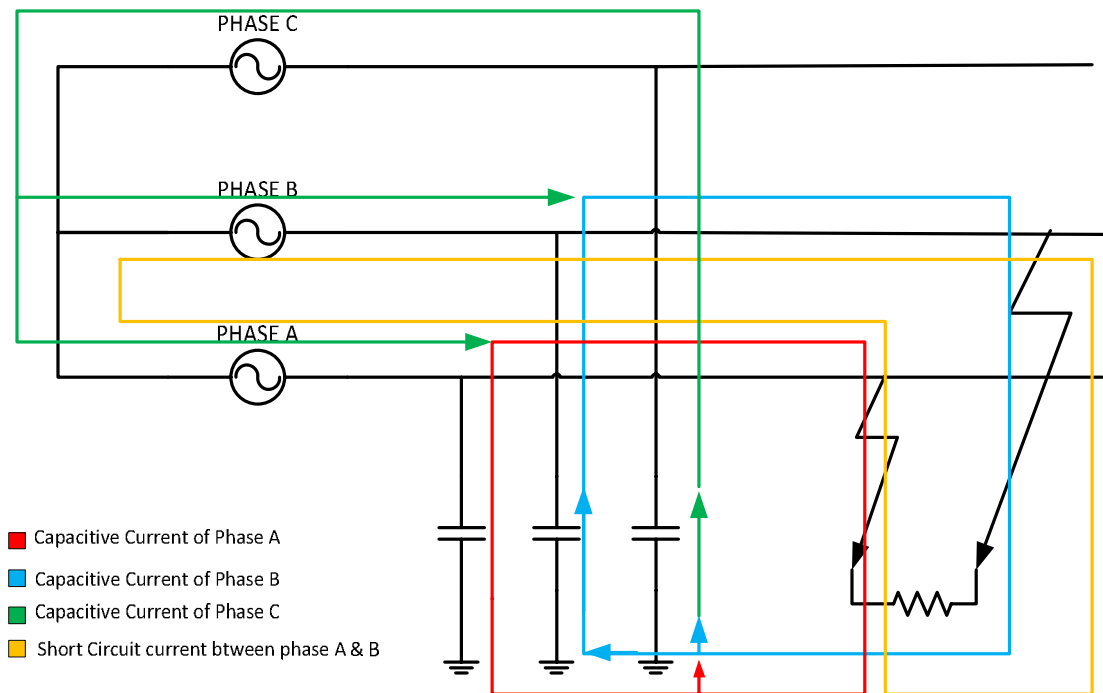

Figure 2.11 Flow of currents as a result of cross country fault on same feeder

Figure 2.11 shows the phase B and phase A is experiencing the phase to earth fault separately at different along the same feeder. The fault locations are different due to this the capacitive current magnitudes of the phase A and B conductors are different. Moreover the due to different fault locations the fault currents have to go through more resistive path in any of the feeder. This difference in the resistance of paths to the flow of currents will allow the conductors of faulty phases to have the sum of capacitive currents from phase A, B and C along with short circuit current through the ground. The short circuit current of cross country faults, through the ground, will have magnitude small as compared to the short circuit current because of not the direct short circuit contact. Due to this sometimes the cross country faults are not detected by the over current protection relays. There are some cases when magnitudes of short circuit currents of cross country faults are even higher than the double phase short circuit's current. This case usually happens when the cross country fault on different feeder.

2.4. Protection from faults in MV network

2.4.1. Directional earth fault protection

Directional earth fault protection relays are used to protect the system from the single phase to earth faults. They use the zero sequence currents and voltage to find if the earth fault has occurred. The angle between these quantities shows the direction of fault. The

complete theory about the fundamentals of directional earth fault protection can be read e.g. from reference [6]. The directional earth fault protection can also be used to protect the network from the cross country fault which is explained in section 2.4.4.

2.4.2. High impedance earth fault indication

High impedance protection indication method protects the medium voltage network from the single phase to earth faults when the fault resistance is very high. These methods are discussed e.g. in reference [1].

2.4.3. Short circuit fault protection

The medium voltage networks are either in ring topology or in the radial topology. In case of the ring topology the direction current protection relays are used for the protection of the network from the short circuit fault. The directional current relays find the direction of the fault current by comparing the phase angle of the voltages and faulty current. After the direction determination the relays operate depending upon on which direction they have to operate. In this way the networks are protected. While in the radial topology network the non-directional current protection relays are sufficient.

2.4.4. Cross country earth fault protection

Differential currents technique

Differential protection is one of the most common methods used in the protection of the equipment. This method is based on the idea of finding the difference of the currents entering and leaving the equipment. The equipment can be i.e. power transformer, generator or transmission line etc. The difference is used to find the type of the fault internal or external. Many computation methods are used in the differential protection like the Fourier transforms. [8] So because of the vast utility of differential protection some methods have been developed based on differential currents techniques to protect the equipment from the cross country faults especially for the power transformers. [9] Also the same methods have been analyzed for the transmission lines. [10] However these methods cannot be used in the Finnish distribution network because the measuring transformers for the currents are available only at the primary substation. There is no measurement of the leaving current from transmission lines at the secondary substation. So that's why there was need to develop a method to protect the network from the cross country faults which only use measurements from primary substation.

Distance relaying technique

The method, based on distance relaying technique, was developed to protect transmission lines from cross country faults on different feeders. The method is using the distance relay protection algorithm to protect the transmission lines [11]. But this method

is dealing only one type of cross country faults which occur on different feeders (parallel transmission lines). [11]

Neural network technique

Another method is developed to detect the cross country earth faults and the intercircuit faults. [12] Intercircuit faults can be taken as the cross country fault on different feeders. The method is based on the neural network technique. The main idea of the method is to model the transmission network in the form of neural network and then a training pattern is needed to make the method to learn about the cross country faults. This method is difficult because you have to make the right learning patterns for the method to work properly. And in the case of the complex networks it becomes more difficult.

Directional earth fault technique

The directional earth fault protection can avoid cross country earth fault. First consider the scenario of the single phase to ground on two feeders. In this scenario the phases are short circuited through the ground. When the fault occur the directional earth fault protection operates only for the feeder where the fault resistance is low as compared to the fault on the other feeder. After the detection of the earth fault on one feeder the circuit breakers of that feeder are opened but the earth fault is still on the other feeder. The directional earth fault protection function detects the fault for the other feeder and then open the other circuit breaker. Hence the cross country fault is avoided.

3. Centralized substation automation system

The distribution automation is the back bone in the protection of medium voltage networks. In order to improve the distribution automation protection systems, the up-gradation of the infrastructure of the protective system is still required. Already many years ago the concept of intelligent electronic devices (IED) has been introduced. Moreover the implementation of IEDs had also led to long maintenance break [14], [15]. So it was thought that such a system which will not require so much infrastructure updates should be developed for the future. The new system should be cost effective and long service breaks should be avoided.

The basic idea behind the solution is to transfer protection functionalities to the centralized computer for enabling a centralized protection system. In this way when the improvement of protection functionalities are required then changes can be performed in the central computer through software and the hardware changes will be avoided. As a result long service breaks and high costs for the up gradation of the systems are avoided [16].

The central computer is made redundant and the protection devices have their own functionalities which are running independently in the protection devices. [14] In the solution the critical protection functions are running on the IEDs and some of the functionalities of these functions are transferred to the central protection computer. For example, information about the status of IEDs is included in the functionalities at the central computer. The central computer based on the statuses of the IEDs updates information about the requirements of the protection. This information enables the protection device to operate according to updated requirements. Now the central computer just act as the device which is tracking the statuses of IEDs and IEDs are actually participating in the real hard protection [16], [15]. The centralized computer also enhances the ability to implement the advanced algorithms which require high computing capacity. These advanced algorithms enable e.g. the central computer to collect the fault reports and upgrade the IEDs through software patches. Hence no hardware upgrading is required [16], [15]. Protection relays are communicating with the central computer through the IEC standard 61850 and through the GOOSE (Generic object oriented substation event) messages with each other. Figure 3.1 shows the basics of architecture of combined centralized computer protection.

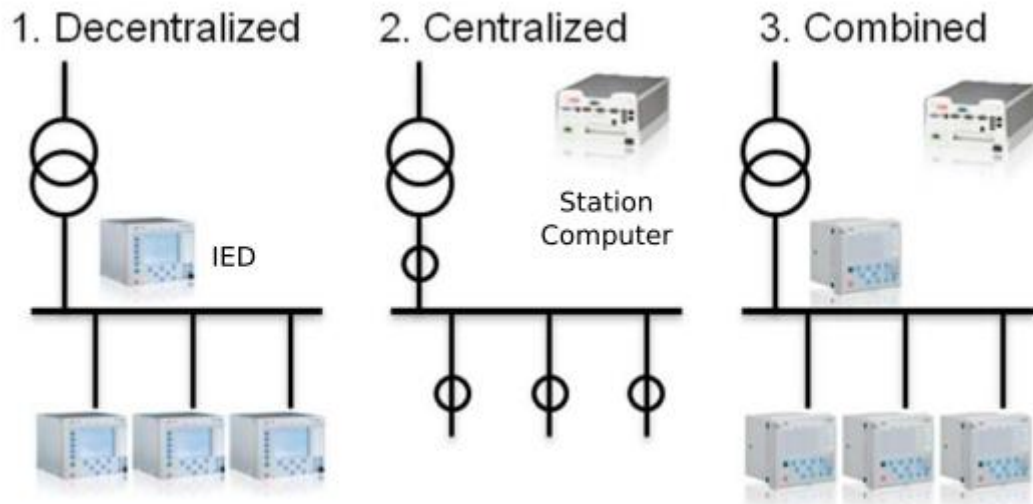

Figure 3.1 Basics of combined centralized computer protection architecture [33]

The protection devices cannot serve the purpose of protection fully and alone. They also need to assist other devices [17]. In this scenario the central computer, containing the status and data of the devices and faults reports, plays important role and provides the protection relays the statuses and data of the other devices. The central computer thus can keep the stack of large amount of data which can be used to develop new security algorithms [16].

3.1. IEC 61850 standard

For a long a time Ethernet protocols has been used as the basics of communication in the substation automation. A new protocol of communication, named as IEC 61850 standards, is built over the Ethernet protocol so there is no need for any hardware changes. Usual Ethernet wires can be used as a physical link for the communication. The main objectives of the IEC 61850: [35]

- Model the different data from the substation which is required for the substation automation by using only single protocol
- Protection devices manufactured by different vendors can communicate easily and hence serve the purpose of substation automation
- Define the techniques to store the data which can be used in fault reports and also for the protection algorithms
- Map the protection and logging features of devices on the communication protocol, hence the device can be updated easily through the software in the future

The main features of the standard IEC 61850 are as follows: [35]

- Data modelling: The protection and control functions of the substations from different IEDs are modelled as logical nodes. These nodes are used to define the

logical devices in the software and hence make us able to form the different logical devices in order to implement the protection algorithm

- Reporting schemes: In the case of any event, the reporting process can be used triggered in order to report the event. The reporting schemes can be triggered based on the predefined protection conditions or triggered conditions.
- Fast transfer of events: The peer to peer communication protocol is named as Generic substation Events (GSE). This is used for the fast reporting of the events. This protocol is further divided in to two categories GOOSE (Generic Object Oriented Substation Events) and GSSE (Generic Substation State Events)
- Setting groups: The setting group controls Blocks (SGCB) are defined to make the user able to make the changes in the protection conditions according to the requirements. It also enables the user to activate or deactivate the device through the setting groups.
- Sampled data transfer: The measured data from the current and voltage transformers are sampled and transferred to the central computer using Sampled Value Control blocks (SVCB). Sampled data transfer also includes method for handling the sampled data.
- Commands: IEC 61850 has included various commands. These commands are provided with more advanced security features. The commands includes the direct and select before operate commands
- Data storage: Use of Substation configuration language has provided the feature to store the configuration data in specific format. Thus efficiency has been increases

The main architecture of the IEC 61850 standard can be easily understood through the figure 3.2. [18]

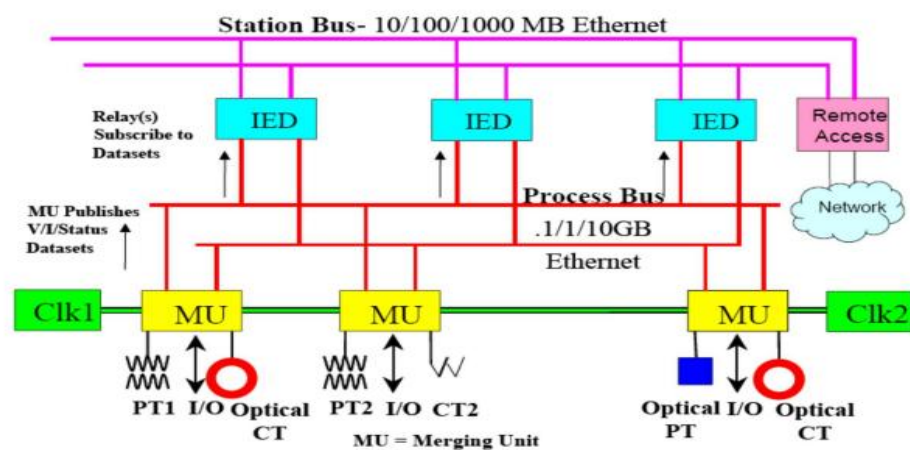

Figure 3.2 The architecture of communication protocol IEC 61850 with process and station buses. [18]

In figure 3.2, MU stands for the measuring unit and the CLK refers to the clock frequency of the measuring units.

The IEC 61850 standard is further divided into many parts based on their functionalities and services. The overall family of IEC 61850 is shown in figure 3.3. [18]

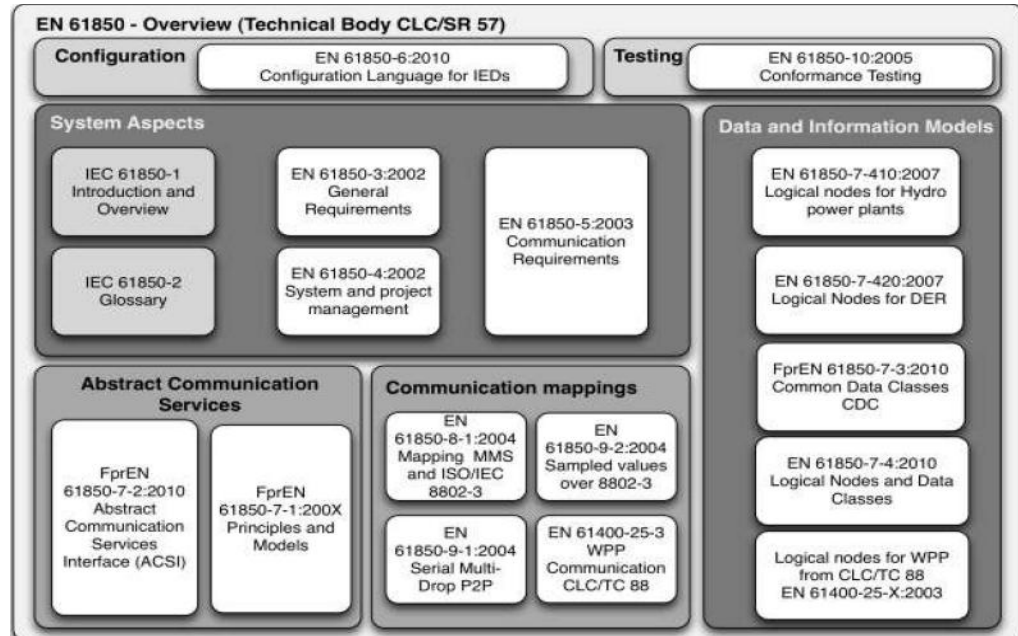

Figure 3.3 The overall family of the IEC 61850 with all its components. [18]

The figure 3.3 tells that IEC 61850 is divided into 10 parts. Each part and its functionality is explained below [19]:

1. Part 1: gives an introduction and overview of the IEC 61850 standard series.
2. Part 2: contains the glossary of specific terminology and definitions used in the context of Substation Automation Systems.
3. Part 3: deals with the specification pertaining to the general requirements of the communication network, with emphasis on the quality requirements. It also deals with guidelines for environmental conditions and auxiliary services and with recommendations on the relevance of specific requirements from other standards and specifications.
4. Part 4: the specifications of this part pertain to the system and project management with respect to the engineering process, the life cycle of the system, and the quality assurance.
5. Part 5: refers to the communication requirements of the functions being performed in the substation automation system.
6. Part 6: Configuration description language for communication in electrical substations related to IEDs
7. Part 7: Basic communication structure for substations and feeder equipment
8. Part 7-1: Principles and models
9. Part 7-2: Abstract Communications Service Interface (ACSI)
10. Part 7-3: Common Data Classes (CDC)

11. Part 7-4: Compatible Logical Node (LN) classes and data classes
12. Part 7-410: Hydroelectric power plants - Communication for monitoring and control
13. Part 7-420: Distributed energy resources (DER) logical nodes
14. Part 8-1: Specific Communications Service Mapping (SCSM) - Mappings to MMS and Ethernet
15. Part 9-1: Specific Communications Service Mapping (SCSM) - Sampled Values over serial unidirectional multi drop point to point link
16. Part 9-2: Specific Communications Service Mapping (SCSM) - Sampled Values over Ethernet (ISO/IEC 8802-3)
17. Part 10: Conformance testing

Let us see the figure 3.4 as an example for the better understanding in the role of each part of IEC 61850 parts at the substation

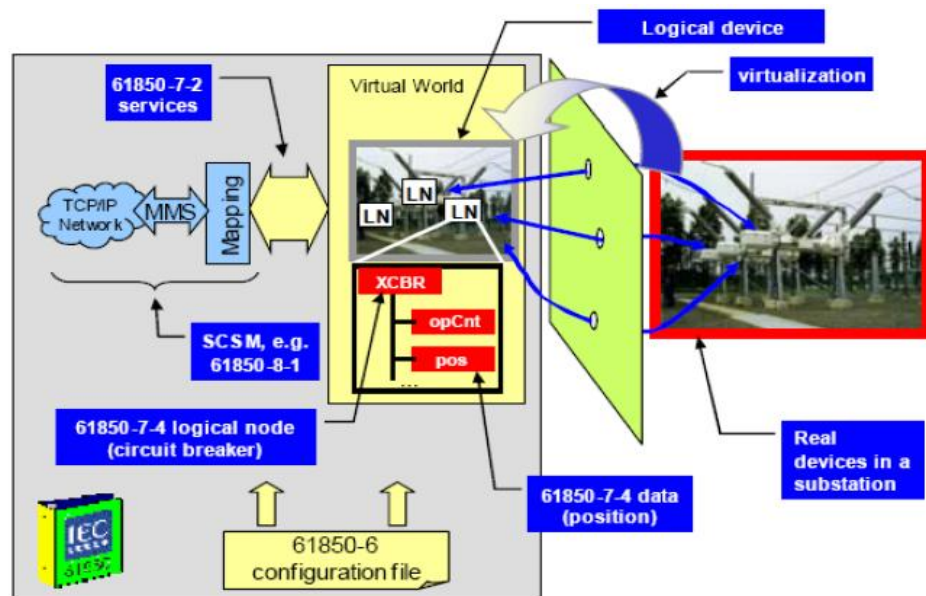

Figure 3.4 Realization of a physical device in the IEC 61850 standard and role of its parts in the realization. [19]

In this thesis we are going to focus on the IEC 61850-9-2 standard. The detail information about the sending of measurement results over the IEC 61850 9-2 standard to research prototype central protection system of ABB is explained in the next section.

3.1.1. Communication architecture in centralized protection and control systems

The IEC 61850 standard is best source of communication in the centralized protection and control system. The IEC 61850 has unique features of modelling the physical devices and use of different logical nodes of different physical devices, to make the different protection functions. Due to these features IEC 61850 is best channel to do configu-

rations in the protection devices (IEDs). The IEC 61850 standard has defined two communication buses. These buses are status bus and the process bus. Status bus is responsible for the communication between protection devices in research prototype central protection system. The GOOSE messages are used to communicate over the status bus [16]. The GOOSE messages are broadcasted directly over the Ethernet cable and the protection devices receives these messages which are of their interest. GOOSE messages are real time messages on the link layer [16], [20]. The process bus is used to send the measured data of the current and voltage transformers, in the form of sampled values, back to the central computer for data logging. The current and voltage transformers measurements are joined together by the merging unit (MU) and they are transmitted over the Ethernet cable [16]. MU is also responsible for the conversion of the measurements from analog to the digital before the measurements are being sent over the Ethernet [16], [21], [22]. The MU has also some information about the status of switches and also some control information for the circuit breakers. The practical use of the process bus by the MU is shown in figure 3.5. [16], [23].

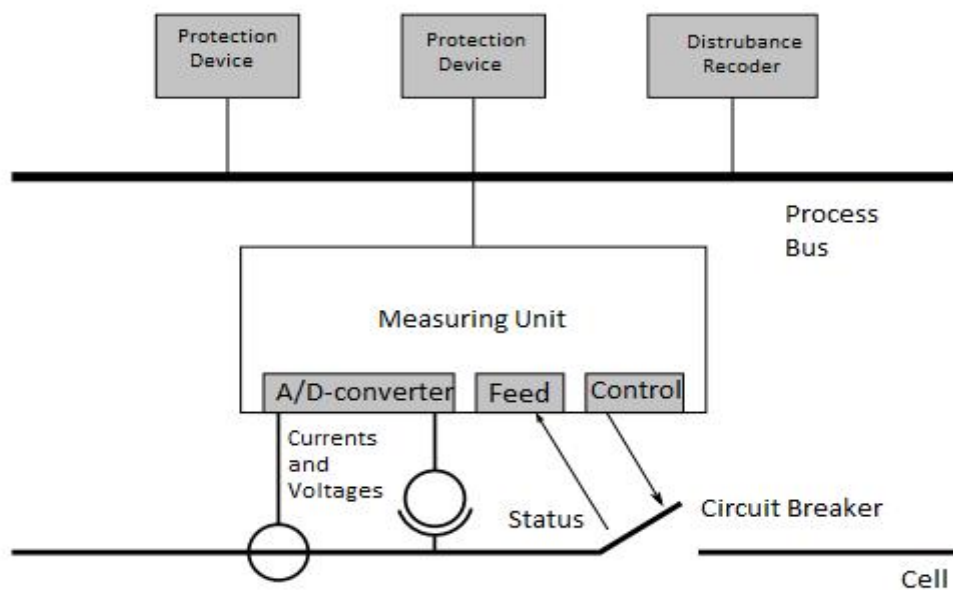

Figure 3.5 An example of the use of process bus. The process MU is connected to the bus, which transmits the measured values of protective devices. [16]

For the first practical implementation of the use of the IEC 61850 standard, standard IEC 61850-9-2 LE (lite edition) was developed. [16]

The Ethernet cable is the physical source for the communication for the buses. Traditionally the protection devices are connected to the measurement unit by several numbers of wires. For example each set of wire for the current and voltage transformers respectively. With each addition of new measurement unit, it requires new set of wires. The IEC 61850-9-2 has defined the process bus which connects many measuring devices to the Ethernet cable through the MU. Thus this has reduced the number of wires.

[16], [21], [24]. Similar advantages of Ethernet cable are for status bus. One of the most important benefits is the less response time between the protection devices which allows faster operation of devices. Due to less response time the numbers of errors are also reduced [16], [25].

3.2. ABB's centralized protection and control research project

ABB has an ongoing research on the centralized protection and control system based on the idea of the redundant role of centralized computers and real hard protection by IEDs. This system will consist of the computer workstation with the software which provides the limited configuration options. The system will use the real time extensions and operates in normal operation system of PC [16]. The component parts of the system are shown in figure 3.6.

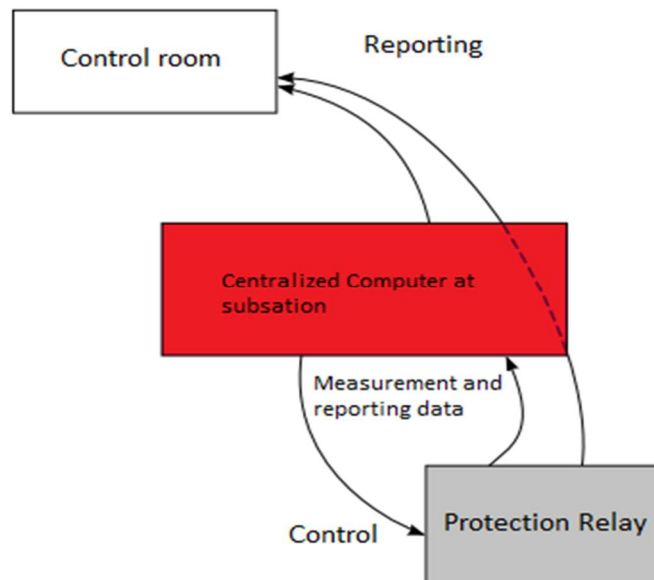

Figure 3.6 A central role of centralized computer. [16]

The system will communicate with the protection devices through the IEC 61850 for sending the configuration settings and to receive the measurement data. The engineering software tool used in the research of centralized protection system is 'PCM600'. [16] The protection tools in ABB's IEDs for overcurrent and earth faults are explained below

3.2.1. Overcurrent protection tool

Overcurrent protection function tool is used to protect the phases from the over current produced as a result of short circuit between two or three phases. The current protection function tool can be directional or non-directional. Usually when there is no distributed

generation in the feeder then non directional current protection is used and vice versa. This function block is divided into three stages (i.e. low, high and instantaneous stages). Low and high stages can be set for either definite time (DT) or inverse definite minimum time (IDMT) modes while the instantaneous stage is only set for the definite time (DT) mode [14]. In DT mode the protection function begins its action after the predefined time and when the fault current disappears it resets the timer for the predefined time. The IDMT mode provides the current dependent timer characteristics. [26] The function block has also the blocking state which is used either to block the timer for the quick action or it may also be used to block the whole function or sometimes its output only.

The internal block diagram of the over current protection function block is shown in figure 3.7. In the figure 3.7 there are five input signals and three output signal. The measurement input port is used to measure the phase currents. The block port is used to disable the whole function, BLKST is used to block the start output of the function, BLKOPER is for blocking the OPERATE output and in the last the FRTIMER is used to freeze the timer from being started. The STDUR is defining the duration between the start timer to the start of operate.

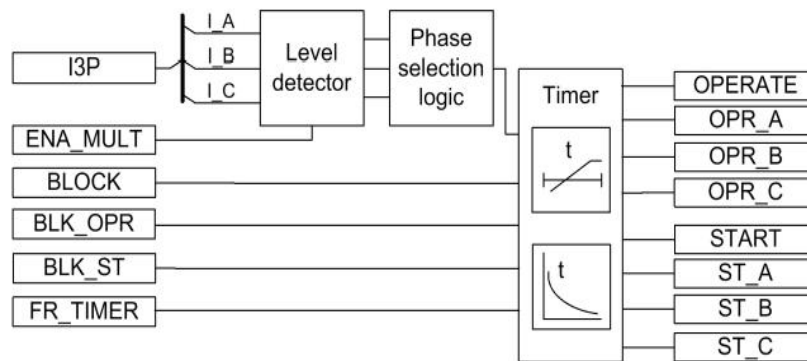

Figure 3.7 Functional module diagram of the current protection tool. [26]

The I3P measures the phase currents. The measured current is compared with the defined limit for the over current protection in the level detector block. The ENA_MULT is an integer value which is multiplied with predefined overcurrent protection level. When the measured current is higher than the limit then the phase selection logic separates the faulty phases and gives the start to signal the timer. The timer behaves depending on the DT or IDMT mode and operates according the defined time curves. When the DT or IDMT timer stops then the operate output is activated. In DT mode when the fault current is lowered then the reset start after the time defined in the start timer while in IDMT mode the reset can be taken place immediate or can also be for the definite time. The timer calculates the start duration value START_DUR, which indicates the percentage ratio of the start situation and the set operating time [26].

3.2.2. Earth fault protection tool

The earth fault protection tool is used to protect the network and feeders from the earth faults. The earth faults include the single phase to ground faults and also along with the existing protection function block from the phase to phase to ground fault. It can also protect the network from the earth faults on multiple feeders which is explained in more detail in the section 2.4.4 of protection of network from cross country earth fault.

The function starts and operates when the operating quantity (current) and polarizing quantity (voltage) exceed the set limits and the angle between them is inside the set operating sector [26]. The basic operation diagram of the directional earth fault protection function block is shown figure 3.8. [26]

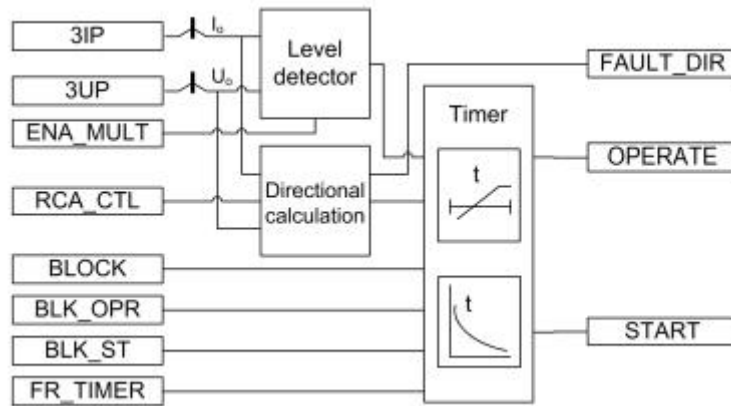

Figure 3.8 Functional module diagram of the directional earth fault protection tool. [26]

The three phase voltage and currents are taken into account for the detection of the earth fault and the same entities are also used for the finding the direction of the earth fault. There is another input named as the RCA_CTL which is use to define if the network is isolated or compensated. The other inputs and outputs are same as described earlier in the section of the overcurrent protection function block.

3.3. Traditional protection against cross country faults

There is no dedicated tool available in the IEDs of ABB to protect the network from the cross country earth faults. Traditionally the directional earth fault protection function along with the overcurrent protection is used to save the network. But there are some cases the overcurrent protection do not detect the short circuit current and the directional earth fault protection function takes longer time to open the relays. Such cases occur in the case of cross country earth fault. One such case can be found e.g. in the reference [36]. The procedure for the protection against cross country faults is same in IEDs of ABB as explained in chapter 2 section 2.4.4.

4. Simulation environment

Before going into the details of the algorithm, we should know about the network which has been used for the development of the algorithm and also used for the testing. The knowledge of the model will help in understanding the behavior of the model in the event of fault. The word ‘behavior’ used here refers to the flow of fault currents as the result of discharging of capacitors from phases to grounds in conductors. Moreover it will help in understanding the algorithm because algorithm is dealing with multiple feeders simultaneously. In the event of a fault, the algorithm includes the information of measured data from other feeders in order to find the exact type of fault.

Next sections throw some light on the softwares which are used for the simulations along with software in which the algorithm has been programmed. But the major focus is on the explanation of the characteristics of the network used.

4.1. Introduction to PSCAD and Matlab

The transient phenomena of the electromagnetic as electromechanical nature can be easily analyze in the EMTP program system, which is universal program. The EMTP is very easy to simulate the complex networks and the control system of arbitrary structure due to its digital base [1]. “EMTDC (which stands for Electromagnetic Transients including DC) is the enhanced version of the EMTP due to its quality of dealing with DC analysis also. EMTDC solves differential equations (for both electromagnetic and electromechanical systems) in the time domain. The power of EMTDC is greatly enhanced by its state-of-the-art graphical user interface called PSCAD. PSCAD allows the user to graphically assemble the circuit, run the simulation, analyze the results, and manage the data in a completely integrated graphical environment.” [27]. The PSCAD is used for the simulations of the faults in this thesis because of the following features of the EMTDC: [27]

- Contingency studies of AC networks consisting of rotating machines, exciters, governors, turbines, transformers, transmission lines, cables, and loads.
- Relay coordination.
- Transformer saturation effects.
- Over-voltages due to a fault or breaker operation.
- Insulation coordination of transformers, breakers and arrestors.
- Investigation of new circuit and control concepts.
- Lightning strikes, faults or breaker operations.

Besides the use of the PSCAD for simulations, Matlab is used to do the analysis of the data generated from the simulations. “MATLAB® is a high-level language and interactive environment for numerical computation, visualization, and programming. Using

MATLAB, you can analyze data, develop algorithms, and create models and applications.” [28].

In the nut shell, the PSCAD is used to create the model of the medium voltage network with three feeders and to simulate the different faults scenarios. Matlab uses the data generated from the PSCAD for the verification of the algorithm. The algorithm is written in the Matlab by higher level language and can easily be modified.

4.2. Model of isolated MV network in PSCAD

The three feeder medium voltage network is modelled in PSCAD. This network is shown in figure 4.1. The big and detailed figure of network shown in fig 4.1 is available in appendix A in figure A.1. In this figure the locations are labelled where the faults will occur e.g. one location is labelled as ‘Point F1_1’. The F1 represent the feeder number and 1 represents the location of fault on the same feeder.

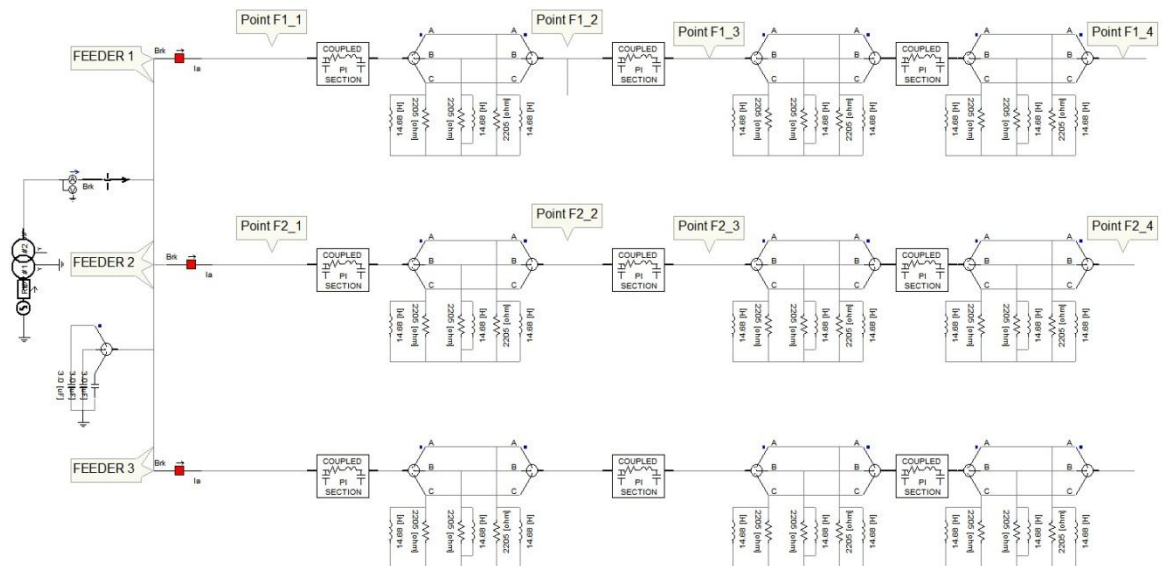

Figure 4.1 The three feeder MV network model in PSCAD

The network consists of primary substation transformer, three feeders, three phase capacitors, breakers, PI sections and loads. The primary substation transformer is in the Y-Y configuration. The neutral point of the winding at the secondary side of transformer is isolated. The three phase capacitors represent the other feeders which are not modelled and act as the background feeders. These capacitors provide part of fault current in case of an earth fault on the feeder. The breakers are used to measure the currents at the beginning of each feeder. Each feeder in the network is consisting of three PI sections. These PI sections are used as coupled configuration. The loads are connected in Y-configuration to the feeders in between the PI sections. This is because loads in the MV network are distributed loads. The loads are symmetrical and selected so that the voltage at the end of the feeder is not dropping more than 95% of 21 kV. This model is based on the model used in the reference e.g. [31]. Each PI section has same parameters on each

feeder. The overall parameters of each PI section used along with the load profile are shown in table 4.1.

Table 4.1 The parameters of each PI section used in three feeders of model shown in figure 4.1

Parameters in per Unit (100MVA, 20 kV Base)							
R	X	B	R0	X0	B0	P[kW]	Q[kVAr]
4.0374	2.3157	3.51E-04	4.9934	11.8283	2.12E-04	200	100

4.3. Introduction to RTDS and RSCAD

The term RTDS stands for the real time digital simulators. This is special designed hardware which simulates the electric power systems in real time. The ability to simulate the networks in real time has enabled RTDS to test the physical devices of control and protection e.g. protection relays. The physical devices can be connected to RTDS through various analogue and digital input/output channels. RTDS hardware is modular in design. This has the ability of enhancement of hardware or using the hardware for specific studies. The Ethernet module of RTDS enables the users to run the simulations simultaneously and the hardware can be accessed remotely. [29] The IEC 61850 standard is also using the Ethernet module of RTDS for the testing of network in implementing the idea of smart grids. Thus enabling us also to make a lab environment to test concept of the centralized protection through central computer along with the IEDs as discussed in chapter 3. Due to this property of RTDS it is also used in the testing of new algorithms which can be implemented in the centralized protection system. How this can be realized, it is discussed in chapter 8.

An RTDS technology has developed a graphical user interface to draw the networks and is used to simulate the network over the hardware. It provides the ability to setup the simulations, control and modify the system parameters during a simulation, data acquisition, and result analysis. RSCAD has vast library of power system, control system and protection and automation components. [30] This can be used to model various networks and perform different case studies. The RSCAD has also a library of components which can be used directly to control the parameters of the hardware and provide the ability to use the hardware in different modes e.g. the Ethernet hardware can be used to download the drafted system to the network and also it can be used as IEC 61850 standard hardware. RSCAD also gives the flexibility of assigning different components to different processors. This will enable the parallel simulations of networks and thus providing real time simulations of RTDS.

4.4. Model of Isolated MV network in RSCAD

The network which is modelled in RSCAD has three medium voltage feeders like the network modelled in PSCAD as described earlier. The model is shown in figure 4.2 Feeder 1 and 3 in fig 4.2 are overhead transmission lines while feeder 2 is a cable feeder.

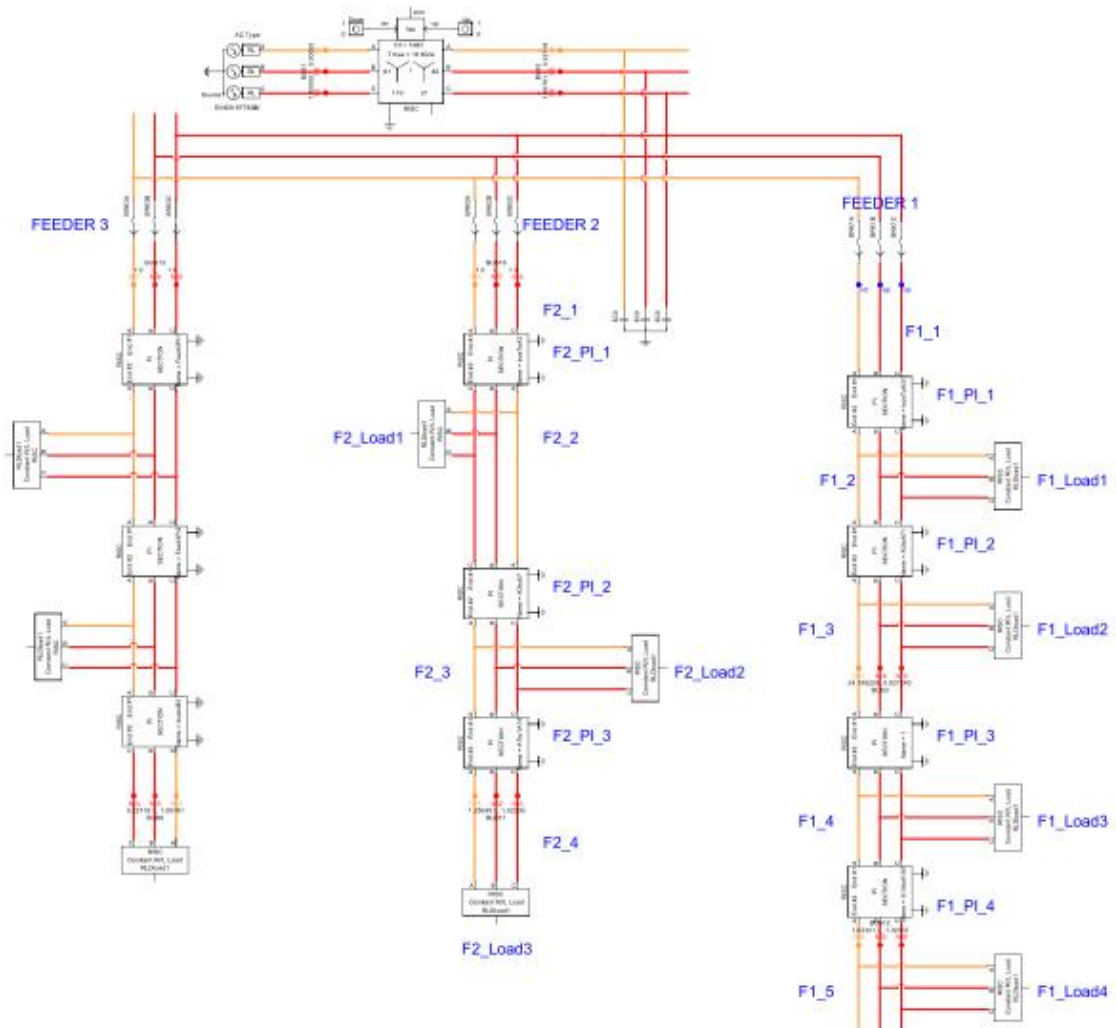

Figure 4.2 The three feeder MV network model in RSCAD for testing in RTDS.

Feeder 3 is same as the feeders used in the PSCAD model described earlier hence its PI section parameters and load profile is same as of the PSCAD model. The parameters of the feeder 1 is shown in table 4.2, whereas their active and reactive power load profiles are shown in table 4.3.

Table 4.2 The electrical Parameter of two Finnish MV network feeders [31]

PI section	Parameters in per Unit (100MVA, 20 kV Base)					
	R	X	B	R0	X0	B0
F1_P1_1	0.834	0.8172	1.59E-04	1.1986	4.4448	9.04E-05
F1_P1_2	1.3275	0.8708	1.17E-04	1.6818	4.3592	7.26E-05
F1_P1_3	1.8759	0.6277	7.50E-05	2.113	3.0243	4.89E-05
F1_P1_4	2.6216	0.9253	1.11E-04	2.9722	4.4725	7.24E-05

Table 4.3 The real and reactive power consumption of feeer1 loads [31]

Node	F1_load1	F1_load2	F1_load3	F1_load4
P[kW]	306.3	493.1	193.8	111.6
Q[kVAr]	87.7	140.7	55.2	31.7

Feeder 2 is, AXAL-TT 12/20(24) kV with conductors size 3x150/35AL, cable feeder. The positive sequence and zeros sequence parameters are same in PI sections. The feeder 2 parameters are shown in table 4.4 [34]. Each load on feeder 2 is same and has values 0.544MW and 0.155MWAR respectively.

Table 4.4 The electrical Parameter of two Finnish MV network feeders [34]

PI section	R	X	B	R0	X0	B0
F2_P1_1	0.618	0.301593	4.613E03	0.618	0.301593	4.613E03
F2_P1_2	0.9476	0.4624	3.01E03	0.9476	0.4624	3.01E03
F2_P1_3	0.5356	0.26138	5.323E03	0.5356	0.26138	5.323E03

5. Algorithm for cross Country fault detection

In the transmission lines, when a single phase is undergone the ground fault then the level of voltage in the healthy phases rises up. This is because the voltage at the neutral point is not zero anymore and to keep the balance of the vectors of voltages, the voltages of the healthy phases rise up. Due to the rise in the voltages, the chances for the other feeders or one of the healthy phases to experience the earth fault increases. Although the single phase to ground fault is detected by the earth fault protection relays but due to slow operating time of earth fault protection relays as compared to over current protection relays, the cross country earth fault can occur due to the over voltages in the healthy phase. Moreover some of the earth faults are permanent and during auto-reclosing of relays, the permanent earth fault can lead to cross country faults due to over voltages in the healthy phases.

In order to make the system more reliable and to reduce the outage cost, there was a need to develop a method which will detect the cross country earth fault. The method should also be able to differentiate between the other faults occurring on the MV network. The next sections will explain the approach of the novel developed method for the detection of the cross country faults, its basics and the explanation of method with an example.

5.1. Flow chart of algorithm

The algorithm will run on each feeder separately. When the cross country fault is detected the algorithm will stop on each feeder and the protective action on the feeder/s will be initiated. The flow chart of algorithm on one feeder is shown in figure 5.1.

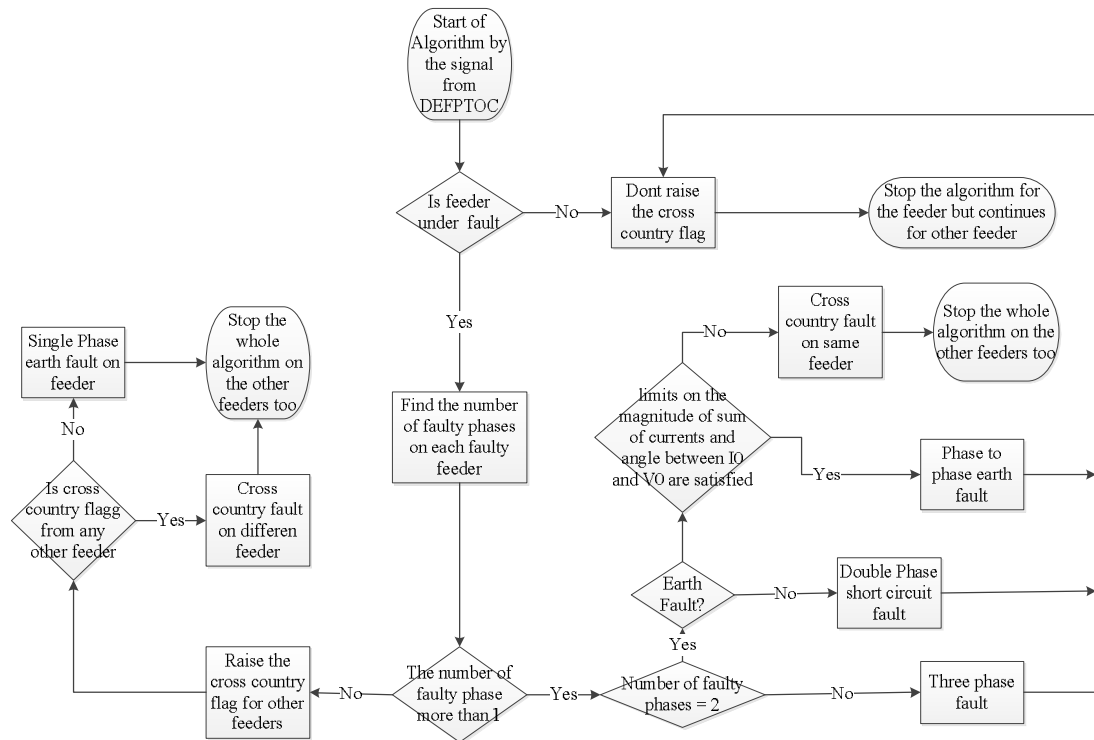

Figure 5.1 The flow chart of algorithm on feeder.

The main of idea of algorithm is that to first get the triggering signal from the directional earth fault protection function (DEFPTOC) from any of the feeder then find whether the feeder is under fault or not. In case of the feeder is under fault then determine the number of the faulty phases. When the number of faulty phase is one then it means that single phase to earth fault occurs. This detection of single phase earth fault will raise a cross country flag. When two feeders will raise this flag then the fault will be declared as cross country fault and terminate the algorithm. But in case of two phase fault determine the type of fault. As the DEFPTOC signal may come from the other feeder so it is necessary to find that whether the double phase fault on that feeder is an earth fault or not i.e. short circuit fault or not. After it is found that it is not short circuit double phase fault by checking the limits defined for the magnitude of sum of combinations of phase currents then determine that the double phase fault is whether cross country fault or phase to phase to earth fault. In case of cross country fault the algorithm on each feeder is stopped. In the end when none feeder is under the cross country fault then algorithm will terminate automatically after the DEFPTOC operating signal is removed.

5.2. Background of algorithm

A simple and basic approach was adopted to solve the problem of the detection of the cross country earth fault. This approach can be classified as the reverse engineering approach. It is because a simple model of three feeders of the MV network was drafted in the simulator and the series of cross country faults were made in the simulations. During the simulations the behavior of the sum of combinations of phase currents were ob-

served. The basic idea behind the sum of the combinations of phase currents is based on the zero sequence current. As it is explained in the second chapter of the thesis that power is delivered to customers through the positive and negative sequence and the zero sequence is used for the detection of the earth faults. That's why the zero sequence current was made as the base for the detection of cross country earth faults. As cross country faults are also the type of the earth faults. Now if we look at the calculation of the zero sequence current calculation formula which is in the equation 5.1. [6]

$$I_0 = \frac{I_A + I_B + I_C}{3} \quad (5.1)$$

In equation 5.1, I_A , I_B and I_C are phase currents. If the phase currents are multiplied by 2 and then break them into further parts as follows

$$I_0 = \frac{I_A + I_B + I_C}{3} = \frac{2*I_A + 2*I_B + 2*I_C}{6} = \frac{I_A + I_B}{6} + \frac{I_B + I_C}{6} + \frac{I_C + I_A}{6} \quad (5.2)$$

In equation 5.2, $I_A + I_B$, $I_B + I_C$ and $I_C + I_A$ which are sum of the combinations of the phase current and they are used to form the base of the method to detect the cross country earth faults. In case of the fault these currents will contain both the load currents and fault current. Let's see what happen when two sine waves of different angles but frequency is same are added. The amplitude can be different or same. The mathematical equation of adding two sine waves is shown in equation 5.3

$$A \sin(\omega t + \alpha) + B \sin(\omega t + \beta) = Mag * \sin(\omega t + \theta) \quad (5.3)$$

$$Mag = \sqrt{[A \cos(\alpha) + B \cos(\beta)]^2 + [A \sin(\alpha) + B \sin(\beta)]^2} \quad (5.4)$$

$$\theta = \tan^{-1} \left[\frac{A \sin(\alpha) + B \sin(\beta)}{A \cos(\alpha) + B \cos(\beta)} \right] \quad (5.5)$$

The magnitude of the resultant sine wave is dependent on the magnitudes and angles of the two adding sine waves. Similarly when the fault will happen then the new magnitude of sum of current will have the contribution of the both magnitudes and angles of two phase currents. Due to this property the addition of sine waves seems to be good reason to use in order to find the cross country fault. The other reason of choosing the sum of the phase currents is explained in the next section. In this way the summation components of the zero sequence current keep the picture of fault intact and can also be used separately to detect the cross country faults.

5.3. Phase currents

Phase currents are very important in determining the type of fault i.e. whether the fault is in single phase, double phases or in three phases. Phase currents can differentiate easily between them. This is one of the obvious uses of the phase currents but in the new method for the detection of the cross country fault phase currents can also be used

to find that if the fault has occurred on the single feeder or multiple feeders. How the phase currents can be used to find this. In order to find the fault on single or multiple feeders, changes in the phase currents are measured. The change is observed in the magnitude and the angle of the phase currents. It is to be noted that phasor form of the phase currents is used in the new method. Let suppose there is fault on the feeder then after getting the signal from the directional earth fault protection function, the next step is to measure the change in the phase currents of all the feeders at the primary substation. If the change in the magnitudes and phases of the phase currents are significant then that feeder is declared as the faulty feeder and the faulty feeder flag is raised. If the change is small then that feeder is not under fault. The significant change can be in either magnitude or phase and to declare the feeder under fault at least two currents should have significant change. Hence phase currents can also be used to find the multiple faulty feeders. Now the question is why we need the sum of the combinations of phase currents. The answer lies in the explanation of phase currents usage. As phase currents are used to differentiate between the single phase and double phase faults. And double phase faults are of different types too as explained in chapter 2 of thesis. The sum of combinations of currents can easily be used to differentiate between the different types of double phase faults. The idea of sum of combinations of phase current is especially used to differentiate the phase to phase to earth fault, phase to phase fault and the cross country fault. In this way this method has general role in finding all types of double phase faults along with cross country earth fault. There are some limitations with this method which are explained in the end of this chapter under the topic of the limitations.

5.4. Basics of methods

This section will explain the basics of each step of the flow chart which is discussed earlier. First the method needs a start signal from directional earth fault protection function (DEFPTOC) from any of the feeder. The DEFPTOC gives signal only when there is an earth fault on any of the feeder and hence will trigger this method on each feeder independently. It should be noted that when the load is changed on any feeder then the method is not triggered as there is no earth fault. Now the further basics of procedure in finding the type of faults are as follows:

- 1) At the first step the method detects the faulty feeder. It is based on the calculation of the change in the feeder's measured sum of combination of currents or phase current. The change is calculated for the magnitude and the angle of the currents. When the change in both the angle and magnitude of at least two measured currents is significant then the feeder will be declared as the faulty feeder otherwise the little change is due to fault on somewhere on any other feeder. The figure 5.2 shows the flow chart of steps

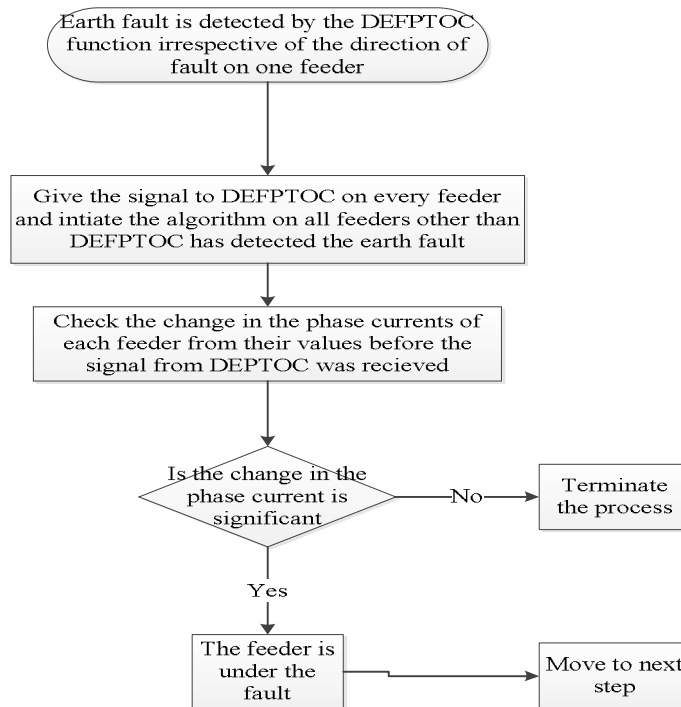

Figure 5.2 Flow chart of steps to find the feeder under an earth fault.

- 2) In second step, the fault is classified as single phase earth fault or double phase earth fault. It can be decided easily on the basis of the phase currents. For example if two phase currents are affected as a result of fault then it is double phase and vice versa. Follow the flow chart as shown in figure 5.3 for the complete understanding

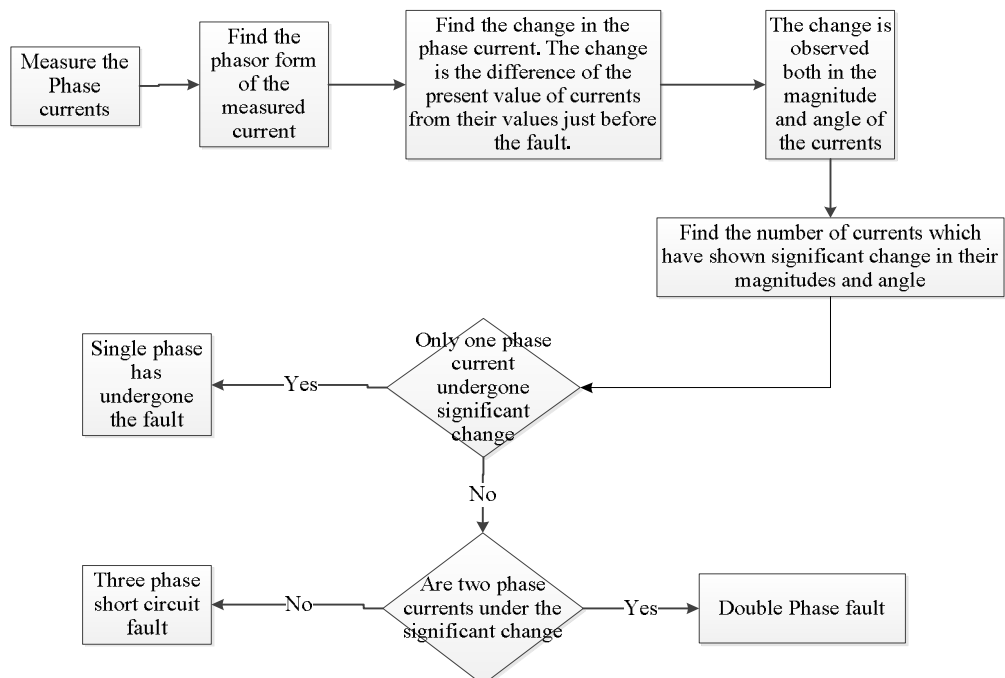

Figure 5.3 The flow chart for finding the number of faulty phases

- 3) When the fault is decided as the single phase then this step will raise the cross country flag for telling other feeders that there is single phase earth fault. It will also differentiate the single phase earth fault from cross country fault by checking if the flag is raised from any other feeder or not. The flag checking procedure will occur only when the fault is detected as single phase fault. The flow chart explaining the this step is shown in figure 5.4

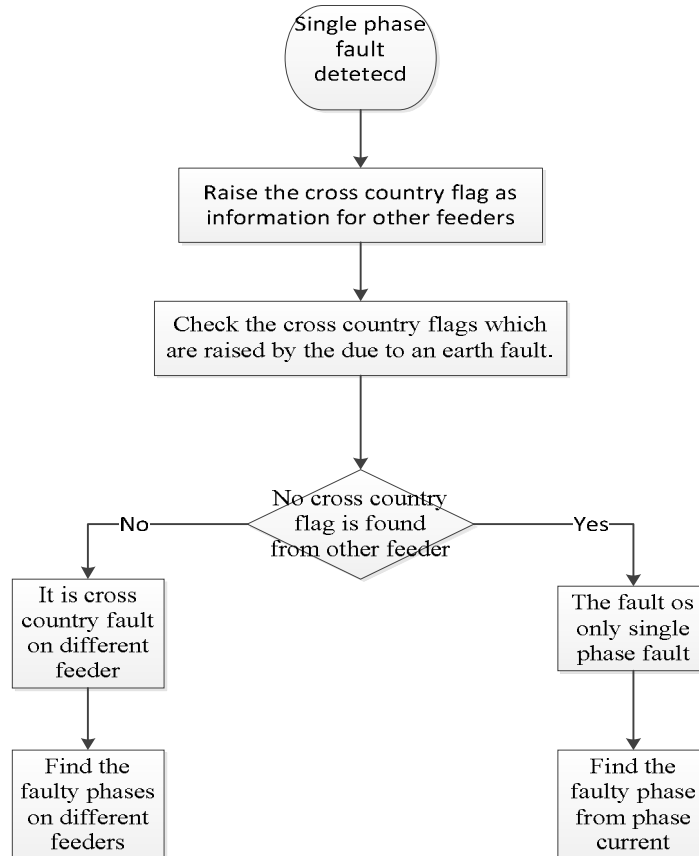

Figure 5.4 The flow chart for finding the cross country fault on different feeder

- 4) This step will separate different type of double phase faults. This will be decided on the basis of the sum of the combinations of the sum of phase currents. First the nature of fault is determined. The fault can be an earthed fault or not. If any of the sums of phase currents have the magnitude and angle close to its initial value then the fault is not an earth fault. When the feeder is not under an earth fault then it will be detected as the double phase short circuit fault and procedure will be terminated for the feeder. This is shown in figure 5.5.

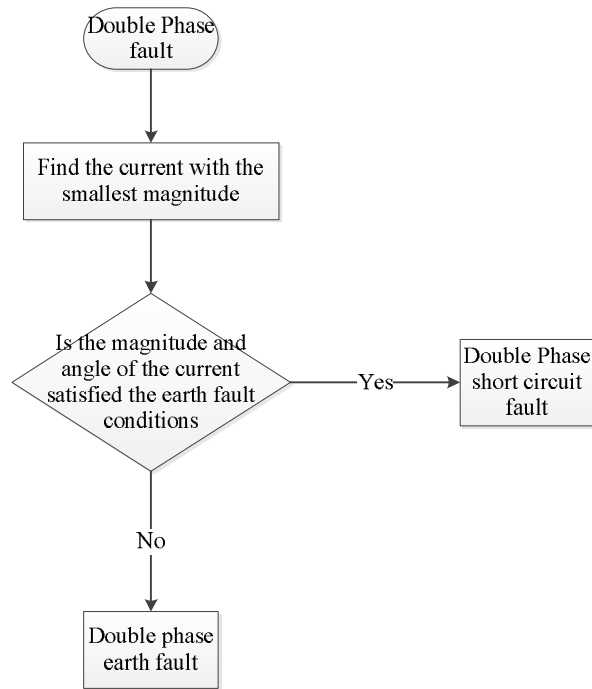

Figure 5.5 Flow chart for finding the double phase earth fault

This step is required because when the algorithm is triggered by the DEFPTOC on the other feeder e.g. feeder 1 and after some time fault occur on the feeder e.g. feeder 2 then the algorithm running on feeder 2 needs to find that what type of fault occur on feeder 2. In this case this step is important.

- 5) After the fault is detected as earth fault then only two types of faults are left i.e. phase to phase to earth fault and cross country fault on same feeder. Three limits have been defined to separate the cross country fault from the phase to phase to earth fault. The limits used in this step are described below:
 - a. Third magnitude limit: This limit is on the magnitude of the sum of the current which has minimum magnitude among the others sum of currents. This limit has two values i.e. minimum and maximum value. Thus this limit defines the range of values for the magnitudes.
 - b. Difference of magnitudes: This limit is defined on the difference between the magnitude of the sum of the currents which are top two high magnitude currents or in other words the difference between the magnitude of sum of currents other than the sum of current who is lowest in magnitude
 - c. Angle limit: This limit is on the angle between the zero sequence current and zero sequence voltage.
 - d. Short circuit current limit: This limit is on the magnitude of the sum of the current that has the highest magnitude among others. It is same as the short circuit current limit but the difference is that this limit is found in case of the phase to phase to earth fault.

When all the four limits are satisfied then the fault is phase to phase to earth fault otherwise it is cross country fault. The reason for defining for limits is

based on the nature of double phase fault. In the case of phase to phase to earth fault, two phases, which are under the fault, should have same magnitude. Although there will be flow of capacitive currents due to an earth fault but the magnitude of short circuit is so high that they can make a little difference. So the difference in magnitude of the currents in fault phases is due to leaking of current to ground. That's why limit is defined on that how much difference is allowed in the sum of currents. The flow chart shown in figure 5.6 tells each step of finding the cross country fault on same feeder

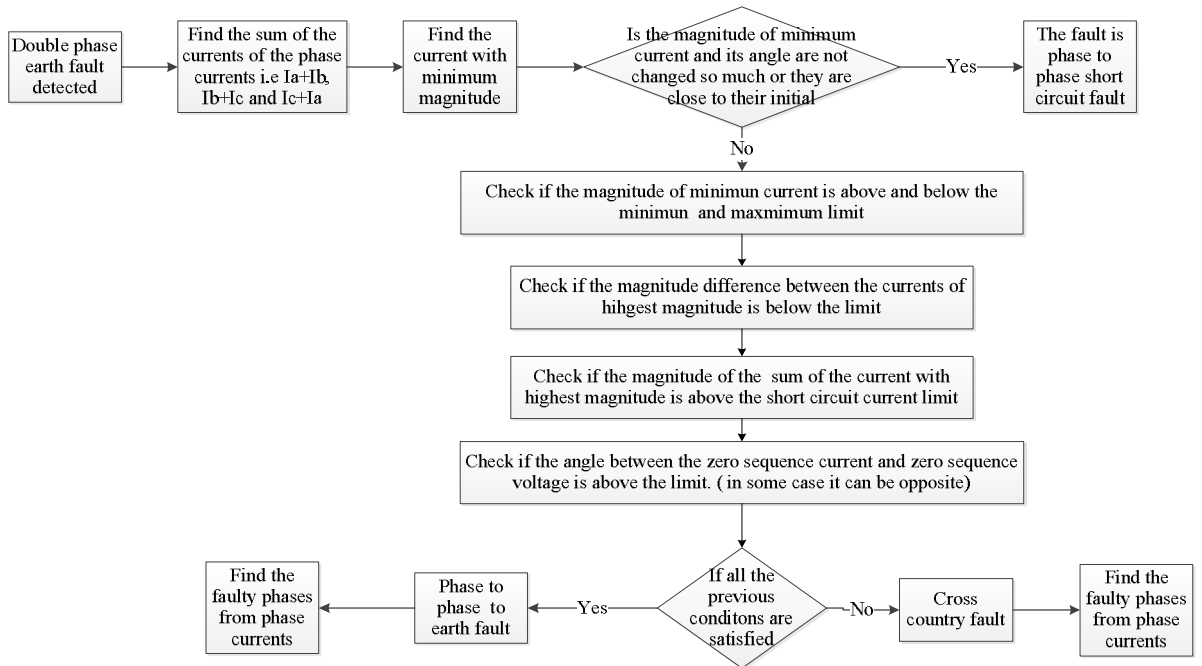

Figure 5.6 The flow chart for finding the cross country fault on same feeder

5.5. Explanation of algorithm

An example can be used to understand the algorithm. Let's take the same MV network which is explained in chapter 4. A cross country fault occurs on feeder 1 only. The other two feeders are not experiencing any fault. In this example, the phase A and B are under the phase to earth fault phenomena at locations 'F1_2' and 'F1_3' respectively as shown in figure 5.7. The earth fault resistance for phase A is $R_a = 0.1$ ohms and for phase B it is $R_b = 0.1$ ohms. The figure 5.7 shows only the feeder 1 of the figure A.1

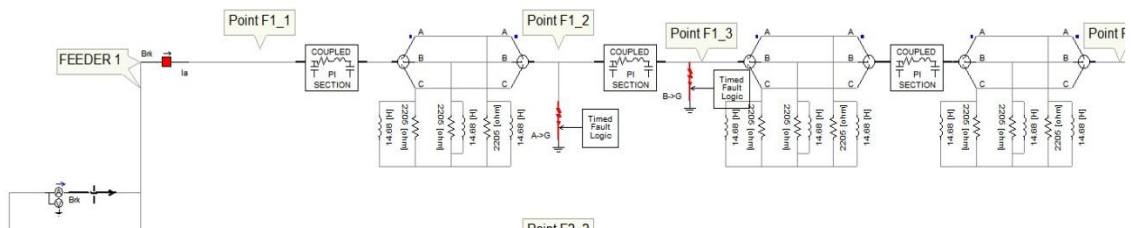

Figure 5.7 Cross country earth fault on same feeder on feeder 1 of the network shown in figure A.1.

When the earth fault occur the directional earth fault function will indicate the occurrence of the earth fault. This indication will be used as the triggering signal for the algorithm on each feeder. The values of the limits used in this example are as follows. These values are found as described by the method in the end of chapter in section 5.6.

- For finding faulty feeder. The feeder will be under fault when at least two sum of combinations of phase currents have change in magnitude more than 0.009 kA and in angle more than 10 degrees
- For finding the earth fault. The fault will be an earth fault when one of the sum of combination of phase currents with lowest magnitude than other two currents has a change in magnitude more than 4 A and for angle, more than 10 degrees.
- For differentiation of phase to phase to earth fault from cross country fault. When the magnitude of sum of currents with lowest magnitude is more than 0.024 kA and below than 0.045 kA, the magnitude difference between two high magnitudes current is less than 0.025 kA, angle between I_0 and V_0 is more than 94 degrees and one of the magnitude of current should be greater than 0.16 kA (short circuit current) then the fault is phase to phase to earth fault. Otherwise cross country fault

Note that magnitude limits will be same for faults in any phase. The only change will be in the angle limit between in I_0 and V_0 . For example when the phases A and B are under fault then the angle between I_0 and V_0 should be more than 94 degrees for the fault to be phase to phase to earth fault. But for the phases B and C and for A and C the angle should be less than 90.4 degrees. The values of angle limits are defined for the model shown in fig 5.7. The procedures to find the values of the limits are explained in the end of the section 5.6. So it is necessary to define these limits separately for the double phase fault depending upon which phases are under fault.

Let's observe the procedure of detection of fault type by the algorithm on each feeder separately after triggering.

Feeder 1:

On feeder 1 the measured phase currents, sum of the combinations of phase currents and the angle between the zero sequence current and voltage, before and after the fault are presented in table 5.1.

Table 5.1. Measured data before and after the fault on feeder 1

Situation	Phase Currents			Sum of combination of phase currents			Angle Between I_0 & V_0
	I_a (kA)	I_b (kA)	I_c (kA)	I_a+I_b (kA)	I_b+I_c (kA)	I_c+I_a (kA)	
Before Fault	0.0164∠0.1308°	0.0164∠241.2189°	0.0164∠121.0462°	0.0164∠0.1496°	0.0164∠241.0339°	0.0164∠120.3186°	90.4°
After Fault	0.3232∠5.1318°	0.2853∠188.4°	0.0161∠116.97°	0.0400∠47.8446°	0.2908∠245.41°	0.3178∠67.85°	99.1°

After the algorithm is triggered, the first step is to find whether the feeder is under the fault or not. For this we have to find the change in the magnitudes and angles of the sum of the combination of currents. The data is presented in table 5.2

Table 5.2. Changes calculated in measured data after the fault

Situation	Phase Currents			Sum of combination of phase currents		
	Ia (kA)	Ib (kA)	Ic (kA)	Ia+Ib (kA)	Ib+Ic (kA)	Ic+Ia (kA)
Change after fault	0.3068∠5°	0.2689∠53°	0.0003∠4°	0.0236∠47°	0.2744∠4°	0.3014∠53°

It can be seen from table 5.2 that two sum of currents have change more than limits defined earlier i.e. change in magnitude more than 0.009 kA and for angle more than 10 degrees. This declares the feeder to be under fault. From table 5.1 the current Ia+Ib has the lowest magnitude as compared to Ib+Ic and Ia+Ic. The next step is determination of whether the fault is single phase or double phase. From table 5.2, the two phase currents have shown significant change in the magnitudes so the fault is double phase fault. The change in the lowest magnitude of sum of current is more than 0.004 kA in magnitude and 10 degrees in angle. This further classifies the fault as the earth fault.

Till now we have the information that feeder is an under earth fault which is double phase fault. As it is an earth fault so there is no chance of phase to phase short circuit fault. This leads us to only find that whether this double phase fault is cross country fault on same feeder or it is phase to phase to earth fault. If we look at the table 5.3, it is found that only one limit is not satisfied. When all the limits will be satisfied then the fault is phase to phase to earth fault. So it is found that fault is cross country fault on the feeder 1.

Table 5.3 Table representing the comparison of limits value with measured values

Limits name	Value of limit	Value measured	Limit satisfied
Short Circuit Magnitude limit	0.16 kA	0.3178 kA	yes
Current with lowest magnitude limit	0.024 – 0.045 kA	0.0400 kA	yes
Difference of magnitude limit	0.025 kA	0.0270 kA	No
Angle b/w Io & Vo	94 degrees	99 degrees	Yes

Feeders 2 and 3:

As the three feeders are having same load profile and same PI section parameters. That's why the measured data for feeder 2 and 3 will be same and represented in table 5.4.

Table 5.4 The measured data for the feeders 2 and 3 before and after the fault

Situation	Phase Currents			Sum of combination of phase currents			Angle Between Io & Vo
	Ia (kA)	Ib (kA)	Ic (kA)	Ia+Ib (kA)	Ib+Ic (kA)	Ic+Ia (kA)	
Before Fault	0.0164∠0.1308°	0.0164∠241.2189°	0.0164∠121.0462°	0.0164∠0.1496°	0.0164∠241.0339°	0.0164∠120.3186°	90.4°
After Fault	0.0146∠-3°	0.0167∠237.8°	0.0170∠125.4°	0.0158∠-9.4°	0.0187∠240.8°	0.0141∠129.2°	93°
Change after fault	0.0018∠3°	0.0003∠3°	0.0006∠6°	0.0006∠9°	0.0023∠0.9°	0.0023∠9°	3

The first step is to find whether the feeder is under fault or not. From table 5.4 we can see the change in the magnitudes and angles is less than 0.009 kA and 10 degree. Due to this the feeders 2 & 3 are not under fault and the algorithm will stop for them

Result:

After the analysis separately on each feeder, it is found that there was a cross country fault. The algorithm correctly identifies the type of the fault. More over when the cross country fault will be found in any of the feeder the algorithm will stop.

5.6. Limits and method to find limits

This section will explain that how we can find the values of the limits used in the algorithm. There are two methods to find the limits .One method is to create equivalent model of MW voltage network in PSCAD and other is to find values of the currents through the mathematical equations. There are total six values of the limits. The procedure to find the values individually is discussed as follows

Faulty feeder limit: To find the value of the limit, for declaring if the feeder is under fault or not, the steps are as follows:

- Find the total load currents of each phase and their sum of currents
- Find the maximum capacitive current of each phase along the whole transmission line. Then measure or calculate the change in the load currents and their sum of currents due to the capacitive currents by adding capacitive current to load currents.
- Perform the short circuit double phase fault on other feeder separately very close to substation and find the voltage change in each phase. Then measure or calculate the how much load currents are changed due to the voltage change as a result of the double phase short circuit fault on the other feeders.
- Observe the maximum change in the sum of the currents caused by the capacitive currents or the rise in voltage due to the short circuit fault on any of the other feeder.

The maximum value of the change in the sum of currents will be the value of faulty feeder limit for that feeder. Perform the above steps of other feeders separately.

Earth fault limit: to find the value of earth fault limit, perform short circuit fault on the feeder for which this value is going to be determined and also perform the double phase short circuit fault on other feeders separately and independently. Observe the maximum change in the phase voltages due to any of the short circuit double phase fault on the same feeder or on other feeders. Find the change in the load currents due to the voltage change for each phase and then find sum of the new load phase currents. Compare the sum of load phase currents before and after the fault. The measure or calculated change will be the value of the earth fault limit value. The double phase short circuit faults are performed with two fault resistances i.e. 0 and 20 ohms.

Short circuit current limit: Perform a phase to phase to earth fault with maximum fault resistance between the phases and the maximum fault resistance of phase to earth fault at the end of the transmission line. The measure and calculate load currents for each phase. Find the sum of the load's phase currents and the value of the maximum magnitude of the sum of the phase currents will be the value of the short circuit current limit.

Angle value between I_o and V_o : Perform a phase to phase to earth fault on the feeder very close to substation with minimum phase to phase fault resistance and maximum phase to earth fault resistance and also with the maximum phase to phase fault resistance and minimum phase to earth fault resistance. Measure or calculate the value of angle between I_o and V_o . The minimum value of either of the combination of fault resistance will be the angle limit value between I_o and V_o .

Difference of magnitude limit: For overhead transmission line perform a phase to phase to earth fault on the feeder very close to substation with maximum phase to phase fault resistance and 100ohms phase to earth fault resistance and for cable transmission line perform a phase to phase to earth fault on the feeder very close to substation with minimum phase to phase fault resistance and minimum phase to earth fault resistance. Measure or calculate the load currents in the case of phase to phase to earth fault. Then perform the following steps

- Find the sum of the loads' phase currents
- Find the sum of the currents who are top two high magnitude currents
- Find the difference between the magnitudes of the sum of currents found in previous step.

The value of the difference in magnitude is the value of the limit.

Third magnitude limit: the value of the limit can be found by performing the phase to phase to earth fault near the primary substation. The values can be found as follows:

Overhead transmission line:

- For lower value of the limit the use the minimum phase to phase fault resistance and maximum or minimum phase to earth fault resistance.
- For the upper value of the limit use 10 ohms phase to phase fault with 100 ohms for phase to earth fault resistance or use 2ohms phase to phase fault resistance with 170 ohms phase to earth fault resistance. The maximum value of either the combination is used as limit.

Cables transmission line:

- For lower value of the limit the use the maximum phase to phase fault resistance and minimum phase to earth fault resistance.
- For the upper value of the limit use 10 ohms phase to phase fault with 100 ohms for phase to earth fault resistance or use 2ohms phase to phase fault resistance

with 170 ohms phase to earth fault resistance. The maximum value of either the combination is used as limit.

In each case measure or calculate the load currents in the case of phase to phase to earth fault. Then perform the following steps

- Find the sum of the loads' phase currents
- Find the sum of the current that has lowest magnitude.

The lower and maximum magnitude of sum of current with lowest magnitude will define the limit range for the third magnitude limit. Note that the algorithm is working fine for following values of resistances:

- Phase to phase fault resistance: max = 20 ohms and min = 0 ohms
- Phase to earth fault resistance: max = 500 ohms and min = 0 ohms

Finding the limits through PSCAD

The equivalent model of the MV voltage network with the three feeders is shown in figure 5.8. This is the same network which is described in chapter 4

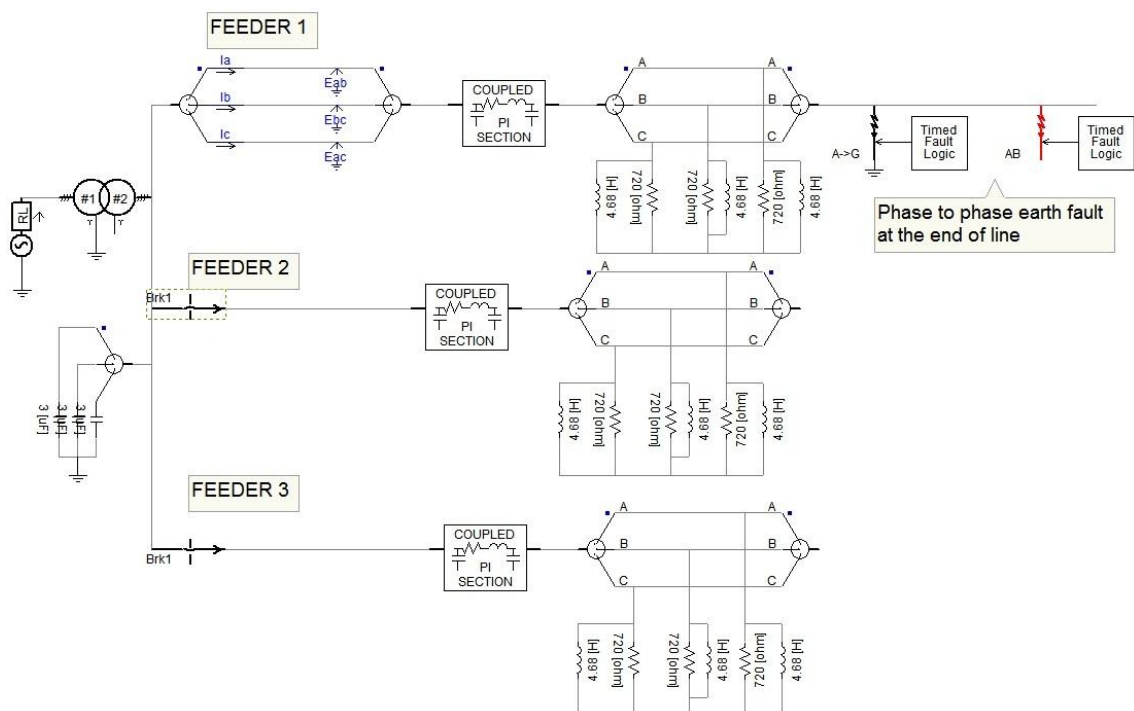

Figure 5.8 the equivalent model of the MV network described in chapter 4.

In figure 5.8 the PI sections are the equivalent of the whole transmission line and the loads are the sum of all the loads attached on the feeder. The limits for differentiating the cross country fault from the phase to phase to earth fault can be found by just doing a phase to phase to earth fault at the line as shown in figure and as described earlier for each feeder separately. Then measure the phase currents and the sum of phase currents to find the limits values.

Finding the limits through equations:

The following equations are used to find the load currents and capacitive currents

$$I_{Load\ per\ phase} = \frac{12\ kV}{load\ impedance} \quad (5.6)$$

$$I_{capacitive\ per\ phase} = 12kV \cdot \omega \cdot C_e \angle 90 \quad (5.7)$$

The loads currents in case of phase to phase earth fault between phase A and B can be found:

$$I_{L_B} = +j\sqrt{3}E_{L1} \left(\frac{Z_0 + 3R_f - aZ_2}{Z_1Z_2 + (Z_1 + Z_2)(Z_0 + 3R_f)} \right) + \sum_{n=2}^N I_{capacitive\ current} \quad (5.8)$$

$$I_{L_A} = +j\sqrt{3}E_{L1} \left(\frac{Z_0 + 3R_f - aZ_2}{Z_1Z_2 + (Z_1 + Z_2)(Z_0 + 3R_f)} \right) + \sum_{n=2}^N I_{capacitive\ current} \quad (5.9)$$

In equation 5.8 and 5.9, N is total number of feeders and Z₀, Z₁ and Z₂ are zero, positive and negative impedances of the whole transmission lines of one feeder respectively. Equations 5.8 and 5.9 will be used when the phase to phase to earth fault occur with phase to phase fault resistance of 0 ohms. In general equations 5.8 and 5.9 can be written as follows

$$I_{L_A} = I_{shortcircuit_AB} - E_{L1} * j\omega C_e\ of\ phase\ C + \sum_{n=2}^N I_{capacitive\ current} \quad (5.10)$$

$$I_{L_B} = -I_{shortcircuit_AB} - E_{L1} * j\omega C_e\ of\ phase\ C + \sum_{n=2}^N I_{capacitive\ current} \quad (5.11)$$

The short circuit current between phases can be found as follows

$$I_{shortcircuit_AB} = \frac{(V_A - V_B)}{R_f + Z_{Transmission\ line} + Z_{transformer} + Z_{source}} \quad (5.12)$$

The voltages V_A and V_B are in phasor form and R_f is the fault resistance between the phases.

6. Simulations and results from PSCAD

The three feeder MV network model was used in PSCAD for the testing of the algorithm. The model is described in chapter 4. The algorithm was programmed in Matlab. The project settings in PSCAD include the feature which enables to store the output of the channels on the disk of computer. The output file from the PSCAD includes the columns of the data. The information about the columns, i.e. which column is representing which data, is given in other file which has an extension of 'infx'. In this way, the current waveforms are saved and can be used for processing. The matlab read the saved files and pass the input waveforms through the algorithm and shows output type of fault on the terminal screen. This chapter will explain the different scenarios of the testing. The behavior of algorithm will be observed during each scenario and the results will be discussed.

6.1. Test cases

The main aim of the algorithm is to detect the cross country earth fault and separate it from the other types of faults e.g. single phase earth fault, short circuit faults and the phase to phase to earth fault. Testing of the algorithm should have all the cases of the faults on MV network. The scenarios designed for the testing of algorithm includes the following cases:

- The single phase to earth fault on each feeder separately and along the different positions of the feeder with different phases. The earth fault resistance is varied from 0 to 500 ohms.
- The phase to phase to earth faults on each feeder separately and along the different positions of the feeder with combination of different phases. The fault resistance between the phases is varied from 0 to 20 ohms while the earth fault resistance is varied from 0 to 500 ohms.
- Short circuit faults on one or different feeders simultaneously at different points on feeder/s with different combination of phases. This case should include an earth fault on the other feeder too. The fault resistance between the phases is varied from 0 to 20 ohms.
- Cross country earth faults on the same feeder with different combination of phases. The earth fault resistance for the each phase is varied from the 0 to 500 ohms.
- Cross country earth faults on different feeders with different combination of phases. The fault resistance for the each phase is varied from the 0 to 500 ohms.

In each case the phase currents and their sum is measured. It should be kept in mind that the algorithm needs a start signal from the direction earth fault protection function

block. Therefore for each case there should be an earth fault on any feeder. Then observe the algorithm output. The measured results are shown in next section. Each case is also discussed how it is differentiating the faults in each case.

6.2. Results and discussions

The figure A.1 is used as reference in each scenario. The limits used in given scenarios below are the same as used in section 5.5 of chapter 5.

6.2.1. Single phase earth fault on one feeder only

As an example a single phase to earth fault is done in phase A of feeder 1 with earth fault resistance of 100 ohms at location labelled as ‘Point F1_3’ as shown in figure A.1. The measured data on each feeder is represented in table 6.1 before and after the fault.

Table 6.1 The measured data from feeder 1 and feeder 2.

Feeder name		Feeder 1			Feeder 2		
Situation		Before fault	After fault	Change after fault	Before fault	After fault	Change after fault
Phase currents	Ia (kA)	0.0164 $\angle 0.1308^\circ$	0.0536 $\angle 54.5^\circ$	0.0372 $\angle 54^\circ$	0.0164 $\angle 0.1308^\circ$	0.0159 $\angle -6^\circ$	0.0005 $\angle 3^\circ$
	Ib (kA)	0.0164 $\angle 241.2189^\circ$	0.0174 $\angle 241^\circ$	0.001 $\angle 0^\circ$	0.0164 $\angle 241.2189^\circ$	0.0182 $\angle 242^\circ$	0.0018 $\angle 3^\circ$
	Ic (kA)	0.0164 $\angle 121.0462^\circ$	0.0159 $\angle 123^\circ$	0.0005 $\angle 2^\circ$	0.0164 $\angle 121.0462^\circ$	0.0153 $\angle 126^\circ$	0.0011 $\angle 5^\circ$
Sum of combination of phase currents	Ia+Ib (kA)	0.0164 $\angle 0.1496^\circ$	0.0364 $\angle 111.5^\circ$	0.02 $\angle 111^\circ$	0.0164 $\angle 0.1496^\circ$	0.0191 $\angle -8^\circ$	0.0025 $\angle 8^\circ$
	Ib+Ic (kA)	0.0164 $\angle 241.0339^\circ$	0.0173 $\angle 247^\circ$	0.0009 $\angle 7^\circ$	0.0164 $\angle 241.0339^\circ$	0.0180 $\angle 252^\circ$	0.0016 $\angle 12^\circ$
	Ic+Ia (kA)	0.0164 $\angle 120.3186^\circ$	0.0612 $\angle 128^\circ$	0.0448 $\angle 8^\circ$	0.0164 $\angle 120.3186^\circ$	0.0128 $\angle 117^\circ$	0.0036 $\angle 3^\circ$
Angle Between I0 & V0		90.4°	90.8°	0.4°	90.4°	90.6°	0.2

On the basis of the table 6.1 the results are summarized in table 6.2.

Table 6.2 The summary of results

Feeder 1				
Limits name	Required response	Value of limit	Value measured	Limit satisfied
Faulty feeder limit	measured value>limit	0.009 \angle 10°	0.02 \angle 111°	yes
Earth fault limit	measured value>limit	0.004 \angle 10°	0.02 \angle 111°	N/a
Number of fault phases	Single phase (A)			
Short circuit magnitude limit	measured value>limit	0.16 kA	n/a as fault is single phase	n/a
Current with lowest magnitude limit	measured value>limit	0.024-0.045 kA	n/a as fault is single phase	n/a
Difference of magnitude limit	measured value<limit	0.025 KA	n/a as fault is single phase	n/a
Angle b/w Io & Vo	measured value>limit	94 degrees	n/a as fault is single phase	n/a
Feeder 2				
Limits name	Required response	Value of limit	Value measured	Limit satisfied
Faulty Feeder limit	measured value>limit	0.009 \angle 10°	0.0036 \angle 3°	No
Earth fault limit	measured value>limit	0.004 \angle 10°	n/a as feeder is not faulty	n/a
Number of fault phases	n/a as feeder is not faulty			
Short Circuit Magnitude limit	measured value>limit	0.16 kA	n/a as feeder is not faulty	n/a
Current with lowest magnitude limit	measured value>limit	0.024 – 0.045 kA	n/a as feeder is not faulty	n/a
Difference of magnitude limit	measured value<limit	0.025 KA	n/a as feeder is not faulty	n/a
Angle b/w Io & Vo	measured value>limit	94 degrees	n/a as feeder is not faulty	n/a

The table 6.2 shows that feeder 1 has the single phase and the fault is in phase A while feeder 2 is not under fault. The results are according to the designed scenario so the algorithm detects the fault correctly.

6.2.2. Phase to phase to earth fault on one feeder only

As an example a phase to phase to earth fault is done at location named as ‘Point F1_4’ as shown in fig A.1. The phase A and B are under the fault in which only phase is also experiencing an earth fault. The earth fault resistance is 100 ohms while the resistance between the two phases is 10 ohms. This fault occurs on feeder 1 while feeder 2 and 3 are not under the fault. As all feeders have same characteristics so only measured data of feeder 1 and feeder 2 is shown in table 6.3.

Table 6.3 The measured data from feeder 1 and feeder 2 in case of the phase to phase to earth fault on feeder 1

Feeder name		Feeder 1			Feeder 2		
Situation		Before fault	After fault	Change after fault	Before fault	After fault	Change after fault
Phase currents	Ia (kA)	0.0164 $\angle 0.1308^\circ$	0.1876 $\angle 15^\circ$	0.1712 $\angle 15^\circ$	0.0164 $\angle 0.1308^\circ$	0.0153 $\angle -2^\circ$	0.0011 $\angle 2^\circ$
	Ib (kA)	0.0164 $\angle 241.2189^\circ$	0.1594 $\angle 202^\circ$	0.143 $\angle 38^\circ$	0.0164 $\angle 241.2189^\circ$	0.0168 $\angle 238^\circ$	0.0004 $\angle 2^\circ$
	Ic (kA)	0.0164 $\angle 121.0462^\circ$	0.0166 $\angle 122^\circ$	0.0002 $\angle 2^\circ$	0.0164 $\angle 121.0462^\circ$	0.0167 $\angle 124^\circ$	0.0003 $\angle 4^\circ$
Sum of combination of phase currents	Ia+Ib (kA)	0.0164 $\angle 0.1496^\circ$	0.0326 $\angle 48^\circ$	0.0162 $\angle 48^\circ$	0.0164 $\angle 0.1496^\circ$	0.0162 $\angle -7^\circ$	0.0002 $\angle 7^\circ$
	Ib+Ic (kA)	0.0164 $\angle 241.0339^\circ$	0.1633 $\angle 256^\circ$	0.1469 $\angle 16^\circ$	0.0164 $\angle 241.0339^\circ$	0.0182 $\angle 242^\circ$	0.0014 $\angle 2^\circ$
	Ic+Ia (kA)	0.0164 $\angle 120.3186^\circ$	0.1838 $\angle 80^\circ$	0.1674 $\angle 80^\circ$	0.0164 $\angle 120.3186^\circ$	0.0146 $\angle 125^\circ$	0.0018 $\angle 5^\circ$
Angle Between I0 & V0		90.4°	96.9°	7°	90.4°	94°	4

The measured data is analyzed and the results are summarized in the table 6.4.

Table 6.4 The results summarized for the phase to phase to earth fault on feeder 1 only

Feeder 1				
Limits name	Required response	Value of limit	Value measured	Limit satisfied
Faulty Feeder limit	measured value > limit	0.009 < 10°	0.1674 < 80°	yes
Earth fault limit	measured value > limit	0.004 < 10°	0.0162 < 48°	Yes
Number of fault phases	Two phase fault (A & B)			
Short Circuit Magnitude limit	measured value > limit	0.16 kA	0.1838 kA	yes
Current with lowest magnitude limit	measured value > limit	0.024-0.045 kA	0.0326 kA	yes
Difference of magnitude limit	measured value < limit	0.025 KA	0.0205kA	yes
Angle b/w Io & Vo	measured value > limit	94 degrees	96.9	yes
Feeder 2				
Limits name	Required response	Value of limit	Value measured	Limit satisfied
Faulty Feeder limit	measured value > limit	0.009 < 10°	0.0018 < 5°	No
Earth fault limit	measured value > limit	0.004 < 10°	n/a as feeder is not faulty	n/a
Number of fault phases	n/a as feeder is not faulty			
Short Circuit Magnitude limit	measured value > limit	0.16 kA	n/a as feeder is not faulty	n/a
Current with lowest magnitude limit	measured value > limit	0.024-0.045 kA	n/a as feeder is not faulty	n/a
Difference of magnitude limit	measured value < limit	0.025 KA	n/a as feeder is not faulty	n/a
Angle b/w Io & Vo	measured value > limit	94 degrees	n/a as feeder is not faulty	n/a

As seen from table 6.4, the feeder 1 has satisfied all the limits set for the detection of the phase to phase to earth fault so the fault is identified as phase to phase to earth fault which is correct. While there is no fault on feeder 2 as clear from table 6.4. Hence there was no cross country fault and the phase to phase to earth fault was successfully determined

6.2.3. Double phase short circuit fault on one feeder only

As an example the double phase to phase fault was done at the location labelled 'Point F1_1' of feeder 1 as shown in figure A.1. This is short circuit fault between phase A and phase B. The resistance of fault between the phases is 10 Ohms. The feeder 2 and 3 has not experienced any fault. The measured data from feeder 1 and feeder 2 is shown in table 6.5.

Table 6.5 Measured data from feeder 1 and feeder 2 in case of short circuit on feeder 1

Feeder name		Feeder 1			Feeder 2		
Situation		Before fault	After fault	Change after fault	Before fault	After fault	Change after fault
Phase currents	Ia (kA)	0.0164 $\angle 0.1308^\circ$	1.7651 $\angle 30^\circ$	1.7487 $\angle 30^\circ$	0.0164 $\angle 0.1308^\circ$	0.0162 $\angle -14^\circ$	0.0002 $\angle 14^\circ$
	Ib (kA)	0.0164 $\angle 241.2189^\circ$	1.7654 $\angle 212^\circ$	1.749 $\angle 28^\circ$	0.0164 $\angle 241.2189^\circ$	0.0125 $\angle 234^\circ$	0.0039 $\angle 6^\circ$
	Ic (kA)	0.0164 $\angle 121.0462^\circ$	0.0164 $\angle 121^\circ$	0.0000 $\angle 0^\circ$	0.0164 $\angle 121.0462^\circ$	0.0164 $\angle 121^\circ$	0.0000 $\angle 1^\circ$
Sum of combination of phase currents	Ia+Ib (kA)	0.0164 $\angle 0.1496^\circ$	0.0164 $\angle 0^\circ$	0.00 $\angle 0^\circ$	0.0164 $\angle 0.1496^\circ$	0.0164 $\angle 0^\circ$	0.0000 $\angle 0^\circ$
	Ib+Ic (kA)	0.0164 $\angle 241.0339^\circ$	1.7651 $\angle 71^\circ$	1.7487 $\angle 71^\circ$	0.0164 $\angle 241.0339^\circ$	0.0162 $\angle 226^\circ$	0.0002 $\angle 14^\circ$
	Ic+Ia (kA)	0.0164 $\angle 120.3186^\circ$	1.7653 $\angle 91^\circ$	1.7489 $\angle 80^\circ$	0.0164 $\angle 120.3186^\circ$	0.0125 $\angle 113^\circ$	0.0039 $\angle 7^\circ$
Angle Between IO & VO		90.4°	90°	0.4°	90.4°	91°	1

The measured data is checked for the defined limits in the algorithm and the results are presented in the table 6.6.

Table 6.6 The results of limits in the case of the short circuit fault on feeder 1

Feeder 1				
Limits name	Required response	Value of limit	Value measured	Limit satisfied
Faulty Feeder limit	measured value > limit	0.009 < 10°	1.7489 < 80°	yes
Earth fault limit	measured value > limit	0.004 < 10°	0.00 < 0°	No
Number of fault phases	Double phase fault			
Short Circuit Magnitude limit	measured value > limit	0.16 kA	n/a as no earth fault detected	n/a
Current with lowest magnitude limit	measured value > limit	0.024-0.045 kA	n/a as no earth fault detected	n/a
Difference of magnitude limit	measured value < limit	0.025 KA	n/a as no earth fault detected	n/a
Angle b/w Io & Vo	measured value > limit	94 degrees	n/a as no earth fault detected	n/a
Feeder 2				
Limits name	Required response	Value of limit	Value measured	Limit satisfied
Faulty Feeder limit	measured value > limit	0.009 < 10°	0.0039 < 7°	No
Earth fault limit	measured value > limit	0.004 < 10°	n/a as feeder is not faulty	n/a
Number of fault phases	n/a as feeder is not faulty			
Short Circuit Magnitude limit	measured value > limit	0.16 kA	n/a as feeder is not faulty	n/a
Current with lowest magnitude limit	measured value > limit	0.024-0.045 kA	n/a as feeder is not faulty	n/a
Difference of magnitude limit	measured value < limit	0.025 KA	n/a as feeder is not faulty	n/a
Angle b/w Io & Vo	measured value > limit	94 degrees	n/a as feeder is not faulty	n/a

The table 6.6 shows clearly that feeder 1 was under the short circuit fault because the condition for the earth fault was not satisfied while feeder 2 was not under any fault. The results obtained from the algorithm are correct.

6.2.4. Double phase short circuit fault and single phase earth fault on two separate feeders simultaneously

This scenario is critical test of the algorithm. In this scenario a double phase short circuit fault with fault resistance of 10 ohms has been done on the feeder 2 at the location labelled as 'Point F2_1' and the single phase to earth fault is done on the feeder 1 at the location labelled as 'Point F1_2' as shown in fig A.1. The ground to earth fault re-

sistance is 50 ohms. On feeder 1 the phase A and on feeder 2 phase A and B are under fault. The data measured from the feeder 1 and feeder 2 is shown in table 6.7.

Table 6.7 Measured data from feeder 1 & 2 in the case of short circuit fault in feeder 2 and single phase to earth fault in feeder 1

Feeder name		Feeder 1			Feeder 2		
Situation		Before fault	After fault	Change after fault	Before fault	After fault	Change after fault
Phase currents	Ia (kA)	0.0164 $\angle 0.1308^\circ$	0.0520 $\angle 55^\circ$	0.0356 $\angle 55^\circ$	0.0164 $\angle 0.1308^\circ$	1.764 1 $\angle 30^\circ$	1.7477 $\angle 14^\circ$
	Ib (kA)	0.0164 $\angle 241.2189^\circ$	0.0139 $\angle 236^\circ$	0.0025 $\angle 4^\circ$	0.0164 $\angle 241.2189^\circ$	1.767 1 $\angle 211^\circ$	1.7507 $\angle 29^\circ$
	Ic (kA)	0.0164 $\angle 121.0462^\circ$	0.0156 $\angle 124^\circ$	0.0008 $\angle 4^\circ$	0.0164 $\angle 121.0462^\circ$	0.015 2 $\angle 126^\circ$	0.0012 $\angle 6^\circ$
Sum of combination of phase currents	Ia+Ib (kA)	0.0164 $\angle 0.1496^\circ$	0.0381 $\angle 115^\circ$	0.0217 $\angle 115^\circ$	0.0164 $\angle 0.1496^\circ$	0.019 4 $\angle -8^\circ$	0.003 $\angle 8^\circ$
	Ib+Ic (kA)	0.0164 $\angle 241.034^\circ$	0.01661 $\angle 235^\circ$	0.0003 $\angle 6^\circ$	0.0164 $\angle 241.034^\circ$	1.768 $\angle 271^\circ$	1.752 $\angle 31^\circ$
	Ic+Ia (kA)	0.0164 $\angle 120.319^\circ$	0.0595 $\angle 129.8^\circ$	0.0431 $\angle 9^\circ$	0.0164 $\angle 120.3186^\circ$	1.763 $\angle 90^\circ$	1.7464 $\angle 30^\circ$
Angle Between I0 & V0		90.4°	91°	1°	90.4°	129°	30

The results obtained after the analysis are shown in table 6.8.

Table 6.8 The results of limits in the case of the short circuit fault on feeder 2 and single phase to earth fault on feeder 1

Feeder 1				
Limits name	Required response	Value of limit	Value measured	Limit satisfied
Faulty Feeder limit	measured value > limit	0.009 $\angle 10^\circ$	0.0217 $\angle 115^\circ$	Yes
Earth fault limit	measured value > limit	0.004 $\angle 10^\circ$	0.0217 $\angle 115^\circ$	Yes
Number of fault phases	Single phase fault (phase A)			
Short Circuit Magnitude limit	measured value > limit	0.16 kA	n/a as fault is single phase	n/a
Current with lowest magnitude limit	measured value > limit	0.024-0.045 kA	n/a as fault is single phase	n/a
Difference of magnitude limit	measured value < limit	0.025 KA	n/a as fault is single phase	n/a
Angle b/w Io & Vo	measured value > limit	94 degrees	n/a as fault is single phase	n/a
Feeder 2				
Limits name	Required response	Value of limit	Value measured	Limit satisfied
Faulty Feeder limit	measured value > limit	0.009 $\angle 10^\circ$	1.752 $\angle 31^\circ$	Yes
Earth fault limit	measured value > limit	0.004 $\angle 10^\circ$	0.003 $\angle 8^\circ$	No
Number of fault phases	Double Phase fault			
Short Circuit Magnitude limit	measured value > limit	0.16 kA	n/a as no earth fault detected	n/a
Current with lowest magnitude limit	measured value > limit	0.024-0.045 kA	n/a as no earth fault detected	n/a
Difference of magnitude limit	measured value < limit	0.025 KA	n/a as no earth fault detected	n/a
Angle b/w Io & Vo	measured value > limit	94 degrees	n/a as no earth fault detected	n/a

The table 6.8 shows that feeder 1 is under the single phase earth fault and feeder 2 is under double phase fault but not an earth fault. The algorithm running on feeder 1 will raise the cross country flag but as the feeder 2 is just under the short circuit fault so the cross country flag will not be raised for this feeder. Hence the algorithm will detect the faults correctly.

6.2.5. Single phase earth fault on two feeder separately in different phases at same time

The feeder 1 and feeder 2 both have under gone the single phase to earth fault. The fault location on feeder 1 is 'Point F1_2' and on feeder it is 'Point F2_4' as shown in figure

A.1. In feeder 1 it is the phase A which is under the earth fault with earth fault resistance of 50 Ohms while on feeder 2 it is phase B with resistance of 200 Ohms. The data measured from both the feeders are shown in table 6.9

Table 6.9 The data measured from feeder 1 and 2 in case of single phase to earth fault on both feeders simultaneously.

Feeder name		Feeder 1			Feeder 2		
Situation		Before fault	After fault	Change after fault	Before fault	After fault	Change after fault
Phase currents	Ia (kA)	0.0164 $\angle 0.1308^\circ$	0.0938 $\angle 36^\circ$	0.0774 $\angle 36^\circ$	0.0164 $\angle 0.1308^\circ$	0.0152 \angle - 7°	0.0012 $\angle 7^\circ$
	Ib (kA)	0.0164 $\angle 241.2189^\circ$	0.0168 $\angle 242^\circ$	0.0004 $\angle 2^\circ$	0.0164 $\angle 241.2189^\circ$	0.06871 \angle 213°	0.05231 $\angle 27^\circ$
	Ic (kA)	0.0164 $\angle 121.0462^\circ$	0.0157 $\angle 122^\circ$	0.0007 $\angle 1^\circ$	0.0164 $\angle 121.0462^\circ$	0.0156 $\angle 128^\circ$	0.0008 $\angle 8^\circ$
Sum of combination of phase currents	Ia+Ib (kA)	0.0164 \angle 0.1 496°	0.0790 \angle 91°	0.0626 \angle 91°	0.0164 \angle 0.1 496°	0.0579 \angle 2 81°	0.0415 \angle 79°
	Ib+Ic (kA)	0.0164 $\angle 241.0339^\circ$	0.0159 $\angle 245^\circ$	0.0005 $\angle 5^\circ$	0.0164 $\angle 241.0339^\circ$	0.0720 $\angle 260^\circ$	0.0556 $\angle 20^\circ$
	Ic+Ia (kA)	0.0164 $\angle 120.3186^\circ$	0.0967 $\angle 105^\circ$	0.0803 $\angle 15^\circ$	0.0164 $\angle 120.3186^\circ$	0.0116 $\angle 122^\circ$	0.0048 $\angle 2^\circ$
Angle Between I0 & V0		90.4°	124°	1°	90.4°	320°	130

The data is analyzed according to the rules set in the algorithm and the results are summarized in the table 6.10.

Table 6.10 The results from data as a result of single phase to earth fault on feeder 1 and 2 simultaneously

Feeder 1				
Limits name	Required response	Value of limit	Value measured	Limit satisfied
Faulty Feeder limit	measured value>limit	0.009∠10°	0.0626∠91°	Yes
Earth fault limit	measured value>limit	0.004∠10°	0.0005∠5°	Yes
Number of fault phases	Single phase fault (phase A)			
Short Circuit Magnitude limit	measured value>limit	0.16 kA	n/a as fault is single phase	n/a
Current with lowest magnitude limit	measured value>limit	0.024-0.045 kA	n/a as fault is single phase	n/a
Difference of magnitude limit	measured value<limit	0.025 KA	n/a as fault is single phase	n/a
Angle b/w Io & Vo	measured value>limit	94 degrees	n/a as fault is single phase	n/a
Feeder 2				
Limits name	Required response	Value of limit	Value measured	Limit satisfied
Faulty Feeder limit	measured value>limit	0.009∠10°	1.752∠31°	Yes
Earth fault limit	measured value>limit	0.004∠10°	0.0048∠2°	n/a
Number of fault phases	Single phase fault (phase B)			
Short Circuit Magnitude limit	measured value>limit	0.16 kA	n/a as fault is single phase	n/a
Current with lowest magnitude limit	measured value>limit	0.024-0.045 kA	n/a as fault is single phase	n/a
Difference of magnitude limit	measured value<limit	0.025 KA	n/a as fault is single phase	n/a
Angle b/w Io & Vo	measured value>limit	94 degrees	n/a as fault is single phase	n/a

From table 6.10 both the faults in separate feeders have been detected as the single phase fault. Cross country fault flag will be raised by both feeders. In the case when two flags are raised then the fault is detected as cross country fault on different feeder. This is correctly detected by the rules of the algorithm.

6.2.6. Phase to phase to earth fault and single phase earth fault on two separate feeders simultaneously

In this scenario feeder 1 has single phase to earth fault in phase A with fault resistance of 80 ohms at location 'Point F1_2' while feeder 2 has phase to phase to earth fault in phase B and C with phase B is to ground through resistance of 50 ohms and the phase C

is short circuited to phase B through resistance of 5 ohms at the location 'Point F2_3' as shown in figure A.1. The data measured from both the feeder are show in table 6.11.

Table 6.11 Measured data of feeder 1 and 2 in case of single phase to earth fault in feeder 1 and phase to phase to earth fault in feeder 2

Feeder name		Feeder 1			Feeder 2		
Situation		Before fault	After fault	Change after fault	Before fault	After fault	Change after fault
Phase currents	Ia (kA)	0.0164 $\angle 0.1308^\circ$	0.1132 $\angle 0^\circ$	0.0968 $\angle 0^\circ$	0.0164 $\angle 0.1308^\circ$	0.0146 $\angle -1^\circ$	0.0018 $\angle 1^\circ$
	Ib (kA)	0.0164 $\angle 241.2189^\circ$	0.0156 $\angle 244^\circ$	0.0008 $\angle 3^\circ$	0.0164 $\angle 241.2189^\circ$	0.2734 $\angle 245^\circ$	0.2571 $\angle 5^\circ$
	Ic (kA)	0.0164 $\angle 121.0462^\circ$	0.0152 $\angle 117^\circ$	0.0012 $\angle 3^\circ$	0.0164 $\angle 121.0462^\circ$	0.2533 $\angle 90^\circ$	0.2369 $\angle 30^\circ$
Sum of combination of phase currents	Ia+Ib (kA)	0.0164 $\angle 0.1496^\circ$	0.1069 $\angle 52^\circ$	0.0905 $\angle 52^\circ$	0.0164 $\angle 0.1496^\circ$	0.2678 $\angle 307^\circ$	0.2514 $\angle 53^\circ$
	Ib+Ic (kA)	0.0164 $\angle 241.0339^\circ$	0.0139 $\angle 241^\circ$	0.0025 $\angle 0^\circ$	0.0164 $\angle 241.0339^\circ$	0.1172 $\angle 237^\circ$	0.1008 $\angle 3^\circ$
	Ic+Ia (kA)	0.0164 $\angle 120.3186^\circ$	0.1073 $\angle 67^\circ$	0.0909 $\angle 53^\circ$	0.0164 $\angle 120.3186^\circ$	0.2534 $\angle 146^\circ$	0.237 $\angle 26^\circ$
Angle Between IO & VO		90.4°	179°	89°	90.4°	33°	57

The results, after the analysis according to the rules of the algorithm, are represented in table 6.12.

Table 6.12 The analyzed results for feeder 1 and 2

Feeder 1				
Limits name	Required response	Value of limit	Value measured	Limit satisfied
Faulty Feeder limit	measured value > limit	0.009 \angle 10°	0.1073 \angle 67°	yes
Earth fault limit	measured value > limit	0.004 \angle 10°	0.0025 \angle 0°	N/a
Number of fault phases	Single phase fault (phase A)			
Short Circuit Magnitude limit	measured value > limit	0.16 kA	n/a as fault is single phase	n/a
Current with lowest magnitude limit	measured value < limit	0.024-0.045 kA	n/a as fault is single phase	n/a
Difference of magnitude limit	measured value > limit	0.025 KA	n/a as fault is single phase	n/a
Angle b/w Io & Vo	measured value > limit	94 degrees	n/a as fault is single phase	n/a
Feeder 2				
Limits name	Required response	Value of limit	Value measured	Limit satisfied
Faulty Feeder limit	measured value > limit	0.009 \angle 10°	0.2514 \angle 53°	Yes
Earth fault limit	measured value > limit	0.004 \angle 10°	0.1008 \angle 3°	yes
Number of fault phases	Double phase fault in B and C			
Short Circuit Magnitude limit	measured value > limit	0.16 kA	0.2678	yes
Current with lowest magnitude limit	measured value > limit	0.024 – 0.2kA	0.1172	yes
Difference of magnitude limit	measured value < limit	0.025 KA	0.0144	yes
Angle b/w Io & Vo	measured value < limit	90 degrees	33°	yes

The table 6.12 shows that fault on feeder 1 and feeder 2 are correctly detected. It is to be noted that on feeder 2 the phase combination for the double phase fault is B and C that's why the limit for the angle between Io and Vo is changed. Also only one cross country flag is raised by feeder 1 so the fault cannot be said cross country fault.

6.2.7. Discussion

From the results of all the cases the algorithm is working fine. Besides the cases large amount of the simulations were done with fault resistance varied from 0 to 20 ohms for the phase to phase fault resistance and 0 to 500 ohms for the phase to earth resistances. These simulations were done mainly for the cross country fault on same feeder. It was observed during the simulations that when the location of fault is very close, in case of cross country fault on same feeder, along with the small resistances of phase to phase

fault and phase to earth fault then algorithm will detect the cross country fault as phase to phase fault. The value of the resistance of phase to earth fault, in case of wrong detection, are from 10 ohms to 30 ohms.

7. Simulations and results from RTDS

Protection algorithms and the devices based on the algorithms are always tested in the real time simulation environment before being implemented in real world. The real time simulators provide us the ability to generate faults in real time and to test how the protection algorithms behave in the real time fault situations. As it is discussed in the chapter 4 section 4.3 about the RTDS, so the cross country fault detection is also tested on the RTDS.

The algorithm is again implemented in the matlab. In the event of the fault the waveforms of phase currents are stored in the ‘COMTRADE’ file format. The ‘COMTRADE’ is standard for the common format for the transient data exchange. The details about the ‘COMTRADE’ can be found in the reference e.g. [32]. In matlab a function to read the COMTRADE file, from the hard disk of computer, is used. This will transform the data in COMTRADE file back to the original data. When the original data in matlab is plotted on the graphs, they are same as the waveforms generated by RTDS. This is easy way to do the analysis according to the rules defined by the algorithm on waveforms in the matlab. In the nutshell, the waveforms are produced by RTDS are stored in COMTRADE files which are read by the matlab to do the analysis.

Same scenarios for testing the algorithm will be used. These scenarios are already discussed in chapter 6. The model which is used for testing is already discussed in chapter 4 section 4.4. The labelled figure of the network in RSCAD is shown in figure 4.2. The next sections are just showing the results and discussions about the results of algorithms when the faults occurred in the real time simulators like RTDS.

7.1. Results and observations

7.1.1. Single phase earth fault on one feeder only.

As an example a single phase to earth fault is done in phase A of feeder 2 (cable feeder) with earth fault resistance of 50 ohms at point labelled as ‘Fault point F2_2 as shown on figure 4.2. While feeder 1 and feeder 3 are not under the fault. The measure data on feeder 1 and 2 is shown in table 7.1.

Table 7.1 the measured data for the single phase to earth fault on feeder 2

Feeder name		Feeder 2			Feeder 1		
Situation		Before fault	After fault	Change after fault	Before fault	After fault	Change after fault
Phase currents	Ia (kA)	0.0449 $\angle -11.83^\circ$	0.0815 $\angle 35^\circ$	0.0366 $\angle 46^\circ$	0.0307 $\angle 2.1727^\circ$	0.0311 $\angle 0.1^\circ$	0.0004 $\angle 2^\circ$
	Ib (kA)	0.0449 $\angle -131.84^\circ$	0.0532 $\angle -129^\circ$	0.0083 $\angle 4^\circ$	0.0307 $\angle -117.83^\circ$	0.0314 $\angle -117.8^\circ$	0.0007 $\angle 0^\circ$
	Ic (kA)	0.0449 $\angle -251.84^\circ$	0.0392 $\angle 117^\circ$	0.0057 $\angle 8^\circ$	0.0307 $\angle -237.83^\circ$	0.0302 $\angle -237^\circ$	0.0005 $\angle 0^\circ$
Sum of combination of phase currents	Ia+Ib (kA)	0.0449 $\angle -11.83^\circ$	0.0351 $\angle 64^\circ$	0.0098 $\angle 65^\circ$	0.0307 $\angle 2.17^\circ$	0.0323 $\angle 1^\circ$	0.0016 $\angle 1^\circ$
	Ib+Ic (kA)	0.0449 $\angle -131.83^\circ$	0.0518 $\angle -113.2^\circ$	0.0069 $\angle 18^\circ$	0.0307 $\angle -117.8^\circ$	0.0312 $\angle -115^\circ$	0.0005 $\angle 2^\circ$
	Ic+Ia (kA)	0.0449 $\angle -251.84^\circ$	0.0939 $\angle -117^\circ$	0.049 $\angle 8^\circ$	0.0307 $\angle -237.8^\circ$	0.0292 $\angle 120^\circ$	0.015 $\angle 3^\circ$
Angle Between I0 & V0		0°	92°	92°	0°	89°	89

The results based on the measured data from table 7.1 are presented in table 7.2

Table 7.2 Summary of results as a result of single phase to earth fault on feeder 2

Feeder 2				
Limits name	Required response	Value of limit	Value measured	Limit satisfied
Faulty Feeder limit	measured value>limit	0.009∠5°	0.0098 ∠65°, 0.049∠8°	yes
Earth fault limit	measured value>limit	0.002∠10°	0.0098 ∠65°	yes
Number of fault phases	Single phase fault (phase A)			
Short Circuit Magnitude limit	measured value>limit	0.778 kA	n/a as fault is single phase	n/a
Current with lowest magnitude limit	measured value>limit	0.039 – 0.064 kA	n/a as fault is single phase	n/a
Difference of magnitude limit	measured value<limit	0.039 kA	n/a as fault is single phase	n/a
Angle b/w Io & Vo	measured value>limit	89.8 degrees	n/a as fault is single phase	n/a
Feeder 1				
Limits name	Required response	Value of limit	Value measured	Limit satisfied
Faulty Feeder limit	measured value>limit	0.009∠10°	0.015 ∠3°, 0.0016∠1°	No
Earth fault limit	measured value>limit	0.004∠10°	n/a as feeder is not faulty	n/a
Number of fault phases	Double phase fault in B and C			
Short Circuit Magnitude limit	measured value>limit	0.27 kA	n/a as feeder is not faulty	n/a
Current with lowest magnitude limit	measured value>limit	0.041-0.06 kA	n/a as feeder is not faulty	n/a
Difference of magnitude limit	measured value<limit	0.046 KA	0 n/a as feeder is not faulty	n/a
Angle b/w Io & Vo	measured value>limit	91.2 degrees	n/a as feeder is not faulty	n/a

As seen from table 7.2, the feeder 2 satisfied only the faulty feeder limit, earth fault limit and the number of faulty phase is one while feeder 1 did not satisfied any limit. In this way feeder 2 is under single phase fault while there is no fault on feeder 1 which is same as we did.

7.1.2. Phase to phase to earth fault on one feeder only.

As an example a phase to phase to earth fault is done in phase A and B of feeder 2 (cable feeder) with earth fault resistance of 10 ohms and phase to phase fault resistance of 5 ohms at point labelled as 'Fault point F2_3 as shown on figure 4.2. While feeder 1 and feeder 3 are not under the fault. The measure data on feeder 1 and 2 is shown in table 7.3

Table 7.3 The measured data of feeder 1 and 2 as result of phase to phase to earth fault

Feeder name		Feeder 2			Feeder 1		
Situation		Before fault	After fault	Change after fault	Before fault	After fault	Change after fault
Phase currents	Ia (kA)	0.0449 $\angle -11.83^\circ$	1.5031 $\angle -22^\circ$	1.4582 $\angle -11^\circ$	0.0307 $\angle 2.1727^\circ$	0.0275 $\angle -32^\circ$	0.0032 $\angle 34^\circ$
	Ib (kA)	0.0449 $\angle -131.84^\circ$	1.4524 $\angle -203^\circ$	1.4075 $\angle 72^\circ$	0.0307 $\angle -117.83^\circ$	0.0146 $\angle -121^\circ$	0.0161 $\angle 4^\circ$
	Ic (kA)	0.0449 $\angle -251.84^\circ$	0.0439 $\angle -253^\circ$	0.001 $\angle 2^\circ$	0.0307 $\angle -237.83^\circ$	0.0306 $\angle -237^\circ$	0.0001 $\angle 0^\circ$
Sum of combination of phase currents	Ia+Ib (kA)	0.0449 $\angle -11.83^\circ$	0.0507 $\angle 36^\circ$	0.0058 $\angle 47^\circ$	0.0307 $\angle 2.17^\circ$	0.0315 $\angle 0^\circ$	0.0008 $\angle 2^\circ$
	Ib+Ic (kA)	0.0449 $\angle -131.83^\circ$	1.4861 $\angle -144^\circ$	1.4412 $\angle 13^\circ$	0.0307 $\angle -117.8^\circ$	0.0275 $\angle -148^\circ$	0.0032 $\angle 31^\circ$
	Ic+Ia (kA)	0.0449 $\angle -251.84^\circ$	1.47 $\angle 38.12^\circ$	1.4251 $\angle 70^\circ$	0.0307 $\angle -237.8^\circ$	0.0127 $\angle 120^\circ$	0.018 $\angle 3^\circ$
Angle Between I0 & V0		0°	95.8598°	95.8598°	0°	271°	271

The results based on the measured data from table 7.3 are presented in table 7.4.

Table 7.4 The summary of result as a result of phase to phase to earth fault on feeder 2

Feeder 2				
Limits name	Required response	Value of limit	Value measured	Limit satisfied
Faulty Feeder limit	measured value>limit	0.009∠5°	1.4251 ∠70°; 1.4412 ∠13°	yes
Earth fault limit	measured value>limit	0.002∠10°	0.0058 ∠47°	yes
Number of fault phases	Double phase fault (phase A and phase B)			
Short Circuit Magnitude limit	measured value>limit	0.778 kA	1.4861	yes
Current with lowest magnitude limit	measured value>limit	0.039 – 0.064 kA	0.0507	yes
Difference of magnitude limit	measured value<limit	0.039 kA	0.0161	yes
Angle b/w Io & Vo	measured value>limit	89.8 degrees	95.85	yes
Feeder 1				
Limits name	Required response	Value of limit	Value measured	Limit satisfied
Faulty Feeder limit	measured value>limit	0.009∠10°	0.018 ∠3°; 0.0008∠2°	No
Earth fault limit	measured value>limit	0.004∠10°	n/a as feeder is not faulty	n/a
Number of fault phases	Double phase fault in B and C			
Short Circuit Magnitude limit	measured value>limit	0.27 kA	n/a as feeder is not faulty	n/a
Current with lowest magnitude limit	measured value>limit	0.041-0.06 kA	n/a as feeder is not faulty	n/a
Difference of magnitude limit	measured value<limit	0.046 KA	0 n/a as feeder is not faulty	n/a
Angle b/w Io & Vo	measured value>limit	91.2 degrees	n/a as feeder is not faulty	n/a

As it is clear from table 7.4 that the fault on feeder 2 satisfied all the limits so it is phase to phase to earth fault while there is no fault on feeder 1. The results are same as it was done in real.

7.1.3. Double phase short circuit fault on one feeder only.

As an example a phase to phase fault is done in phase A and B of feeder 2 (cable feeder) with phase to phase fault resistance of 15 ohms at point labelled as 'Fault point F2_1 as shown on figure 4.2. While feeder 1 and feeder 3 are not under the fault. The measure data on feeder 1 and 2 is shown in table 7.5

Table 7.5 The measured data of feeder 1 and 2 as result of phase to phase fault on feeder 2

Feeder name		Feeder 2			Feeder 1		
Situation		Before fault	After fault	Change after fault	Before fault	After fault	Change after fault
Phase currents	Ia (kA)	0.0449 $\angle -11.83^\circ$	1.1416 $\angle -5^\circ$	1.0967 $\angle -6^\circ$	0.0307 $\angle 2.1727^\circ$	0.0313 $\angle -21^\circ$	0.0006 $\angle 23^\circ$
	Ib (kA)	0.0449 $\angle -131.84^\circ$	1.1239 $\angle -183^\circ$	1.079 $\angle 52^\circ$	0.0307 $\angle -117.83^\circ$	0.0194 $\angle -131^\circ$	0.0113 $\angle 15^\circ$
	Ic (kA)	0.0449 $\angle -251.84^\circ$	0.0450 $\angle -252^\circ$	0.0001 $\angle 0.0^\circ$	0.0307 $\angle -237.83^\circ$	0.0307 $\angle -237.8^\circ$	0.0001 $\angle 0^\circ$
Sum of combination of phase currents	Ia+Ib (kA)	0.0449 $\angle -11.83^\circ$	0.0449 $\angle -11.6^\circ$	0.00 $\angle 0^\circ$	0.0307 $\angle 2.17^\circ$	0.0307 $\angle -141^\circ$	0.000 $\angle 143^\circ$
	Ib+Ic (kA)	0.0449 $\angle -131.83^\circ$	1.1416 $\angle -125^\circ$	1.0967 $\angle 6^\circ$	0.0307 $\angle -117.8^\circ$	0.0313 $\angle -141^\circ$	0.0006 $\angle 24^\circ$
	Ic+Ia (kA)	0.0449 $\angle -251.84^\circ$	1.1239 $\angle 56^\circ$	1.079 $\angle 53^\circ$	0.0307 $\angle -237.8^\circ$	0.0194 $\angle -251^\circ$	0.0113 $\angle 14^\circ$
Angle Between I0 & V0		0°	-5°	5°	0°	-183°	-183

The results based on the measured data from table 7.5 are presented in table 7.6.

Table 7.6 The summary of result as a result of phase to phase fault on feeder 2

Feeder 2				
Limits name	Required response	Value of limit	Value measured	Limit satisfied
Faulty Feeder limit	measured value>limit	0.009 \angle 5°	1.079 \angle 53°, 1.0967 \angle 6°	yes
Earth fault limit	measured value>limit	0.002 \angle 10°	0.00 \angle 0°	no
Number of fault phases	n/a as no earth fault			
Short Circuit Magnitude limit	measured value>limit	0.778 kA	n/a as no earth fault	n/a as no earth fault
Current with lowest magnitude limit	measured value>limit	0.039 – 0.064 kA	n/a as no earth fault	n/a as no earth fault
Difference of magnitude limit	measured value<limit	0.039 kA	n/a as no earth fault	n/a as no earth fault
Angle b/w Io & Vo	measured value>limit	89.8 degrees	n/a as no earth fault	n/a as no earth fault
Feeder 1				
Limits name	Required response	Value of limit	Value measured	Limit satisfied
Faulty Feeder limit	measured value>limit	0.009 \angle 10°	0.000 \angle 143, 0.0006 \angle 24°	No
Earth fault limit	measured value>limit	0.004 \angle 10°	n/a as feeder is not faulty	n/a
Number of fault phases	Double phase fault in B and C			
Short Circuit Magnitude limit	measured value>limit	0.27 kA	n/a as feeder is not faulty	n/a
Current with lowest magnitude limit	measured value>limit	0.041-0.06 kA	n/a as feeder is not faulty	n/a
Difference of magnitude limit	measured value<limit	0.046 KA	0 n/a as feeder is not faulty	n/a
Angle b/w Io & Vo	measured value>limit	91.2 degrees	n/a as feeder is not faulty	n/a

As it is clear from table 7.6 that the fault on feeder 2 satisfied only faulty feeder limit and it did not satisfy the earth fault limit so it is phase to phase fault while there is no fault on feeder 1. The results are same as it was done in real.

7.1.4. Double phase short circuit fault and single phase earth fault on two feeders separately.

As an example a phase to phase fault is done in phase A and B of feeder 2 (cable feeder) with phase to phase fault resistance of 0.1 ohms at point labelled as 'Fault point F2_1' and single phase fault in phase B of feeder 1 with fault resistance of 0.1 ohms at point labelled as 'Fault point F1_2' as shown on figure 4.2. While feeder 3 are not under the fault. The measure data on feeder 1 and 2 is shown in table 7.7

Table 7.7 The measured data of feeder 1 and 2

Feeder name		Feeder 2			Feeder 1		
Situation		Before fault	After fault	Change after fault	Before fault	After fault	Change after fault
Phase currents	Ia (kA)	0.0449 $\angle -11.83^\circ$	2.3229 $\angle -54^\circ$	2.278 $\angle -43^\circ$	0.0307 $\angle 2.1727^\circ$	0.0160 $\angle -58^\circ$	0.0147 $\angle 60^\circ$
	Ib (kA)	0.0449 $\angle -131.84^\circ$	2.282 $\angle 126^\circ$	2.2371 $\angle 202^\circ$	0.0307 $\angle -117.83^\circ$	0.0344 $\angle 17^\circ$	0.0037 $\angle 225^\circ$
	Ic (kA)	0.0449 $\angle -251.84^\circ$	0.0454 $\angle 113.7^\circ$	0.0005 $\angle 6^\circ$	0.0307 $\angle -237.83^\circ$	0.0308 $\angle 123^\circ$	0.0001 $\angle 0^\circ$
Sum of combination of phase currents	Ia+Ib (kA)	0.0449 $\angle -11.83^\circ$	0.0466 $\angle -22.6^\circ$	0.0017 $\angle 11^\circ$	0.0307 $\angle 2.17^\circ$	0.0412 $\angle 55^\circ$	0.0105 $\angle 53^\circ$
	Ib+Ic (kA)	0.0449 $\angle -131.83^\circ$	2.3264 $\angle 186^\circ$	2.2815 $\angle 42.2^\circ$	0.0307 $\angle -117.8^\circ$	0.0398 $\angle 126^\circ$	0.0091 $\angle 116^\circ$
	Ic+Ia (kA)	0.0449 $\angle -251.84^\circ$	2.2785 $\angle 6^\circ$	2.2336 $\angle 102^\circ$	0.0307 $\angle -237.8^\circ$	0.0148 $\angle 183^\circ$	0.0159 $\angle 60^\circ$
Angle Between I0 & V0		0°	-89°	89°	0°	91.6°	92

The results based on the measured data from table 7.7 are presented in table 7.8.

Table 7.8 The summary of result as a result of phase to phase fault on feeder 2 and single phase fault on feeder 1

Feeder 2				
Limits name	Required response	Value of limit	Value measured	Limit satisfied
Faulty Feeder limit	measured value > limit	0.009 $\angle 5^\circ$	2.2336 $\angle 102^\circ$, 2.2815 $\angle 42.2^\circ$	yes
Earth fault limit	measured value > limit	0.002 $\angle 10^\circ$	0.0017 $\angle 11^\circ$	no
Number of fault phases	n/a as no earth fault			
Short Circuit Magnitude limit	measured value > limit	0.778 kA	n/a as no earth fault	n/a as no earth fault
Current with lowest magnitude limit	measured value > limit	0.039 – 0.064 kA	n/a as no earth fault	n/a as no earth fault
Difference of magnitude limit	measured value < limit	0.039 kA	n/a as no earth fault	n/a as no earth fault
Angle b/w I_o & V_o	measured value > limit	89.8 degrees	n/a as no earth fault	n/a as no earth fault
Feeder 1				
Limits name	Required response	Value of limit	Value measured	Limit satisfied
Faulty Feeder limit	measured value > limit	0.009 $\angle 10^\circ$	0.0159 $\angle 60^\circ$, 0.0105 $\angle 53^\circ$	Yes
Earth fault limit	measured value > limit	0.004 $\angle 10^\circ$	0.0091 $\angle 116^\circ$	Yes
Number of fault phases	Single phase fault (phase B)			
Short Circuit Magnitude limit	measured value > limit	0.27 kA	n/a as single phase fault	n/a
Current with lowest magnitude limit	measured value > limit	0.041-0.06 kA	n/a as single phase fault	n/a
Difference of magnitude limit	measured value < limit	0.046 kA	n/a as single phase fault	n/a
Angle b/w I_o & V_o	measured value > limit	91.2 degrees	n/a as single phase fault	n/a

As it is clear from table 7.8 that the fault on feeder 2 satisfied only faulty feeder limit and it did not satisfy the earth fault limit so it is phase to phase fault while there is single phase fault on feeder 1. The results are same as it was done in real.

7.1.5. Single phase earth fault on two feeders separately in different phases at the same time.

As an example a single phase earth fault is done in phase A of feeder 2 (cable feeder) with fault resistance of 10 ohms at point labelled as 'Fault point F2_2' and single phase earth fault in phase B of feeder 1 with fault resistance of 50 ohms at point labelled as 'Fault point F2_3' as shown on figure 4.2. While feeder 3 are not under the fault. The measure data on feeder 1 and 2 is shown in table 7.9

Table 7.9. The measured data of feeder 1 and 2

Feeder name		Feeder 2			Feeder 1		
Situation		Before fault	After fault	Change after fault	Before fault	After fault	Change after fault
Phase currents	Ia (kA)	0.0449 $\angle -11.83^\circ$	0.3023 $\angle 5^\circ$	0.2574 $\angle 16^\circ$	0.0307 $\angle 2.1727^\circ$	0.0294 $\angle -7^\circ$	0.0013 $\angle 9^\circ$
	Ib (kA)	0.0449 $\angle -131.84^\circ$	0.0478 $\angle 229^\circ$	0.0029 $\angle 1^\circ$	0.0307 $\angle -117.83^\circ$	0.2599 $\angle 205^\circ$	0.2292 $\angle 37^\circ$
	Ic (kA)	0.0449 $\angle -251.84^\circ$	0.0397 $\angle 114^\circ$	0.0052 $\angle 4.8^\circ$	0.0307 $\angle -237.83^\circ$	0.0300 $\angle 127^\circ$	0.0007 $\angle 4.8^\circ$
Sum of combination of phase currents	Ia+Ib (kA)	0.0449 $\angle -11.83^\circ$	0.2697 $\angle 58^\circ$	0.248 $\angle 69^\circ$	0.0307 $\angle 2.17^\circ$	0.2361 $\angle -90^\circ$	0.2054 $\angle 92^\circ$
	Ib+Ic (kA)	0.0449 $\angle -131.83^\circ$	0.0476 $\angle 240^\circ$	0.0027 $\angle 11^\circ$	0.0307 $\angle -117.8^\circ$	0.2676 $\angle 260^\circ$	0.2369 $\angle 17.8^\circ$
	Ic+Ia (kA)	0.0449 $\angle -251.84^\circ$	0.2919 $\angle 73^\circ$	0.247 $\angle 35.2^\circ$	0.0307 $\angle -237.8^\circ$	0.0225 $\angle 121^\circ$	0.0052 $\angle 1.2^\circ$
Angle Between I0 & V0		0°	154°	154°	0°	-18°	18

The results based on the measured data from table 7.9 are presented in table 7.10.

Table 7.10 The summary of result as a result of single earth fault on feeder 2 and single phase fault on feeder 1

Feeder 2				
Limits name	Required response	Value of limit	Value measured	Limit satisfied
Faulty Feeder limit	measured value > limit	0.009 $\angle 5^\circ$	0.247 $\angle 35.2^\circ$, 0.248 $\angle 69^\circ$	yes
Earth fault limit	measured value > limit	0.002 $\angle 10^\circ$	0.0027 $\angle 11^\circ$	yes
Number of fault phases	Single phase fault phase A			
Short Circuit Magnitude limit	measured value > limit	0.778 kA	n/a as single phase fault	n/a
Current with lowest magnitude limit	measured value > limit	0.039 – 0.064 kA	n/a as single phase fault	n/a
Difference of magnitude limit	measured value < limit	0.039 kA	n/a as single phase fault	n/a
Angle b/w I_o & V_o	measured value > limit	89.8 degrees	n/a as single phase fault	n/a
Feeder 1				
Limits name	Required response	Value of limit	Value measured	Limit satisfied
Faulty Feeder limit	measured value > limit	0.009 $\angle 10^\circ$	0.2369 $\angle 17.8^\circ$, 0.2054 $\angle 92^\circ$	Yes
Earth fault limit	measured value > limit	0.004 $\angle 10^\circ$	0.0052 $\angle 1.2^\circ$	Yes
Number of fault phases	Single phase fault (phase B)			
Short Circuit Magnitude limit	measured value > limit	0.27 kA	n/a as single phase fault	n/a
Current with lowest magnitude limit	measured value > limit	0.041-0.06 kA	n/a as single phase fault	n/a
Difference of magnitude limit	measured value < limit	0.046 kA	n/a as single phase fault	n/a
Angle b/w I_o & V_o	measured value > limit	91.2 degrees	n/a as single phase fault	n/a

As it is clear from table 7.10 that the fault on feeder 2 satisfied only faulty feeders limit the earth fault limit so it is single phase fault while there is single phase fault on feeder 1. The two feeders raised the cross country flags and the fault is cross country fault. The results are same as it was done in real.

7.1.6. Phase to phase to earth fault on one feeder and single phase to earth fault on other feeder separately at the same time.

As an example a phase to phase to earth fault is done in phase A and B of feeder 2 (cable feeder) with phase to phase fault resistance of 0.1 ohms and earth fault resistance of 20 ohms at point labelled as 'Fault point F2_2' and single phase earth fault in phase C of feeder 1 with fault resistance of 0.1 ohms at point labelled as 'Fault point F2_3' as

shown on figure 4.2. While feeder 3 are not under the fault. The measure data on feeder 1 and 2 is shown in table 7.11

Table 7.11. The measured data of feeder 1 and 2

Feeder name		Feeder 2			Feeder 1		
Situation		Before fault	After fault	Change after fault	Before fault	After fault	Change after fault
Phase currents	Ia (kA)	0.0449 $\angle -11.83^\circ$	2.2191 $\angle 307^\circ$	2.1742 $\angle 42^\circ$	0.0307 $\angle 2.1727^\circ$	0.0133 $\angle -50^\circ$	0.0174 $\angle 52^\circ$
	Ib (kA)	0.0449 $\angle -131.84^\circ$	1.9772 $\angle 136^\circ$	1.9323 $\angle 185^\circ$	0.0307 $\angle -117.83^\circ$	0.0081 $\angle -86^\circ$	0.0226 $\angle 31^\circ$
	Ic (kA)	0.0449 $\angle -251.84^\circ$	0.0375 $\angle 101^\circ$	0.0074 $\angle 7.2^\circ$	0.0307 $\angle -237.83^\circ$	0.4038 $\angle -259^\circ$	0.3731 $\angle 22^\circ$
Sum of combination of phase currents	Ia+Ib (kA)	0.0449 $\angle -11.83^\circ$	0.4078 $\angle 318^\circ$	0.363 $\angle 31^\circ$	0.0307 $\angle 2.17^\circ$	0.0204 $\angle -3^\circ$	0.0103 $\angle 5^\circ$
	Ib+Ic (kA)	0.0449 $\angle -131.83^\circ$	2.0079 $\angle 196^\circ$	1.963 $\angle 32^\circ$	0.0307 $\angle -117.8^\circ$	0.3958 $\angle -199^\circ$	0.3654 $\angle 82^\circ$
	Ic+Ia (kA)	0.0449 $\angle -251.84^\circ$	2.1855 $\angle 367^\circ$	2.141 $\angle 258^\circ$	0.0307 $\angle -237.8^\circ$	0.3291 $\angle -200^\circ$	0.2984 $\angle 37^\circ$
Angle Between I0 & V0		0°	313°	313°	0°	130°	130

The results based on the measured data from table 7.11 are presented in table 7.12.

Table 7.12 The summary of result as a result of phase to phase to earth fault on feeder 2 and single phase fault on feeder 1

Feeder 2				
Limits name	Required response	Value of limit	Value measured	Limit satisfied
Faulty Feeder limit	measured value > limit	0.009 $\angle 5^\circ$	2.141 $\angle 258^\circ$, 1.963 $\angle 32^\circ$	yes
Earth fault limit	measured value > limit	0.002 $\angle 10^\circ$	0.363 $\angle 31$	yes
Number of fault phases	Double phase fault phase A and B			
Short Circuit Magnitude limit	measured value > limit	0.778 kA	2.1855	yes
Current with lowest magnitude limit	measured value > limit	0.039 – 0.064 kA	0.4078	yes
Difference of magnitude limit	measured value < limit	0.039 kA	0.1775 phase fault	yes
Angle b/w I_o & V_o	measured value > limit	89.8 degrees	304	yes
Feeder 1				
Limits name	Required response	Value of limit	Value measured	Limit satisfied
Faulty Feeder limit	measured value > limit	0.009 $\angle 10^\circ$	0.3654 $\angle 82^\circ$, 0.2984 $\angle 37^\circ$	Yes
Earth fault limit	measured value > limit	0.004 $\angle 10^\circ$	0.0103 $\angle 5^\circ$	Yes
Number of fault phases	Single phase fault (phase C)			
Short Circuit Magnitude limit	measured value > limit	0.27 kA	n/a as single phase fault	n/a
Current with lowest magnitude limit	measured value > limit	0.041-0.06 kA	n/a as single phase fault	n/a
Difference of magnitude limit	measured value < limit	0.046 kA	n/a as single phase fault	n/a
Angle b/w I_o & V_o	measured value > limit	91.2 degrees	n/a as single phase fault	n/a

As it is clear from table 7.12 that the fault on feeder 2 satisfied all limits so it is phase to phase to earth phase fault while there is single phase fault on feeder 1. The results are same as it was done in real.

7.1.7. Cross country fault on same feeder.

As an example a cross country fault is done in phase A and B of feeder 2 (cable feeder) with phase fault resistance of 20 ohms at point labelled as 'Fault point F2_2' and phase B fault resistance 0.1 ohms at point labelled as 'Fault point F2_3' as shown on figure 4.2. While feeder 1 and feeder 3 are not under the fault. The measure data on feeder 1 and 2 is shown in table 7.13

Table 7.13 The measured data of feeder 1 and 2 as result of cross country fault on feeder 2

Feeder name		Feeder 2			Feeder 1		
Situation		Before fault	After fault	Change after fault	Before fault	After fault	Change after fault
Phase currents	Ia (kA)	0.0449 $\angle -11.83^\circ$	0.8464 $\angle -1^\circ$	0.8015 $\angle 10^\circ$	0.0307 $\angle 2.1727^\circ$	0.0310 $\angle -14^\circ$	0.0003 $\angle 16^\circ$
	Ib (kA)	0.0449 $\angle -131.84^\circ$	0.8107 $\angle 183^\circ$	0.7658 $\angle 45^\circ$	0.0307 $\angle -117.83^\circ$	0.0232 $\angle 230^\circ$	0.0075 $\angle 12.2^\circ$
	Ic (kA)	0.0449 $\angle -251.84^\circ$	0.0501 $\angle 111.7^\circ$	0.0052 $\angle 3.5^\circ$	0.0307 $\angle -237.83^\circ$	0.0311 $\angle 122^\circ$	0.0004 $\angle 0.2^\circ$
Sum of combination of phase currents	Ia+Ib (kA)	0.0449 $\angle -11.83^\circ$	0.0757 $\angle -0.3^\circ$	0.0308 $\angle 11^\circ$	0.0307 $\angle 2.17^\circ$	0.0298 $\angle -0^\circ$	0.0009 $\angle 3^\circ$
	Ib+Ic (kA)	0.0449 $\angle -131.83^\circ$	0.8275 $\angle 240.5^\circ$	0.7826 $\angle 12^\circ$	0.0307 $\angle -117.8^\circ$	0.0326 $\angle 225^\circ$	0.0019 $\angle 17^\circ$
	Ic+Ia (kA)	0.0449 $\angle -251.84^\circ$	0.8285 $\angle 62^\circ$	0.7836 $\angle 46^\circ$	0.0307 $\angle -237.8^\circ$	0.0227 $\angle 114^\circ$	0.008 $\angle 8.2^\circ$
Angle Between I0 & V0		0°	95.86°	95.86°	0°	-89°	-89

The results based on the measured data from table 7.13 are presented in table 7.14.

Table 7.14 The summary of result as a result of phase to phase fault on feeder 2

Feeder 2				
Limits name	Required response	Value of limit	Value measured	Limit satisfied
Faulty Feeder limit	measured value>limit	0.009∠5°	0.7836 ∠46°, 0.7826 ∠12°	yes
Earth fault limit	measured value>limit	0.002∠10°	0.0308 ∠11°	yes
Number of fault phases	Double phase fault (A and B)			
Short Circuit Magnitude limit	measured value>limit	0.778 kA	0.8285	yes
Current with lowest magnitude limit	measured value>limit	0.039 – 0.064 kA	0.0757	no
Difference of magnitude limit	measured value<limit	0.039 kA	0.001 kA	yes
Angle b/w Io & Vo	measured value>limit	89.8 degrees	95	yes
Feeder 1				
Limits name	Required response	Value of limit	Value measured	Limit satisfied
Faulty Feeder limit	measured value>limit	0.009∠10°	0.008 ∠8.2°, 0.0009∠3°	No
Earth fault limit	measured value>limit	0.004∠10°	n/a as feeder is not faulty	n/a
Number of fault phases	Double phase fault in B and C			
Short Circuit Magnitude limit	measured value>limit	0.27 kA	n/a as feeder is not faulty	n/a
Current with lowest magnitude limit	measured value>limit	0.041-0.06 kA	n/a as feeder is not faulty	n/a
Difference of magnitude limit	measured value<limit	0.046 KA	0 n/a as feeder is not faulty	n/a
Angle b/w Io & Vo	measured value>limit	91.2 degrees	n/a as feeder is not faulty	n/a

As it is clear from table 7.14 that the fault on feeder 2 did not satisfy only third magnitude limit so it is cross country fault while there is no fault on feeder 1. The results are same as it was done in real.

7.1.8. Observations

During the simulation of the cross country fault on same feeder 1 or 2 with resistances changing from 0.1 ohms to 500ohms, it was observed that when fault the resistance is in between 10-30 ohms in one phase and 0.1 ohms to 10 ohms in other phase along with the small distance between two fault points e.g. less than 3 km then cross country fault is detected as phase to phase earth fault. This is limitation of the algorithm but it is good in one sense because over current protection relay will operate and hence the feeder will be protected. Moreover the wrong detection of the fault is also due to the limits values

which are derived from extreme values of the resistances e.g. the phase to phase fault resistance is ranging from 0.1 ohms to 20 ohms in this algorithm but generally it is few ohms and also the phase to earth resistance is from 0 to 500 ohms but in reality this range can be small. So if we test the algorithms with real values then the number of wrong detection of faults are reduced.

8. Implementation possibilities of developed method in centralized protection and control system.

The developed method needs a triggering signal. This triggering signal can be provided by the directional earth fault protection (DEFPTOC) function block of IEDs of ABB. As the DEFPTOC is the part of IED and IED is the basic block of the central protection and control system so it will also be easy to implement this method in centralized protection system. In other words we can say that this method will be actually the extension of DEFPTOC. The current DEFPTOC need some changes in order to implement this method in centralized protection system. The proposed changes are explained in the next section. The proposed changes are not difficult in the nature and method is just based on the 'if and else' logic. This will help to say that implementation of method for the detection of cross country earth fault in the research prototype central protection system of ABB is feasible.

8.1. Proposed changes in DEFPTOC of IED

The following changes should be made in order to make the DEFPTOC function to detect the cross country faults:

- The new DEFPTOC should communicate with the DEFPTOCs on the other feeders.
- The DEFPTOC can be triggered also by any of the DEFPTOC on other feeders by sending start signal over the communication channel.
- The new DEFPTOC will not require finding the direction of the earth fault.
- The new DEFPTOC should broadcast the information i.e. whether the feeder is under the earth fault or not, to all the new DEFPTOCs.
- The new DEFPTOC will have smaller time period for the action against the cross country faults as compared to the traditional DEFPTOC.

After the implementation of proposed changes the algorithm can be appended in the DEFPTOC. The mathematics of the method is not difficult to implement.

8.2. Proposed timing operation

The new DEFPTOC including cross country fault detection algorithm would have better protection against the cross country faults in terms of time of the operation. The figure 8.1 shows the time performance of the new DEFPTOC.

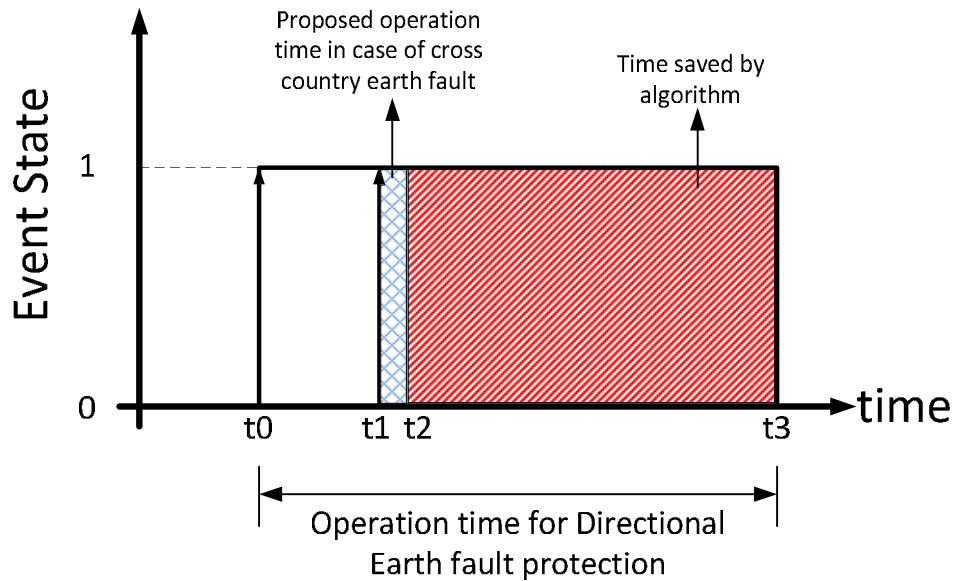

Figure 8.1 Timing diagram of the operation of the DEFPTOC and new DEFPTOC.

Let's consider that an earth fault occur on one feeder at time t_0 as shown in fig 8.1. The total operation time for the conventional DEFPTOC is $t_3 - t_0$ as shown in fig 8.1. According to the algorithm new DEFPTOC will began to run on each feeder as long as the cross country fault is detected or the operation time of the conventional DEFPTOC ends. Let's suppose that during the time between $t_3 - t_0$ another fault occur on the other feeder or same feeder at time t_1 as shown in fig 8.1. As the algorithm is running on each feeder so the type of the fault will be detected. If the fault is detected as cross country fault then algorithm will take immediate action like an over current protection function, this is shown as blue shaded region till time t_2 in fig 8.1. Otherwise the algorithm will keep running until the earth fault signal of the conventional DEFPTOC vanishes. As it is shown in fig 8.1 that the operation time of new DEFPTOC in response to cross country fault is small and it saves the time which is shown by red shaded region so the performance of the new DEFPTOC is faster than conventional DEFPTOC in case of cross country fault. This faster performance of the new DEFPTOC based on the developed algorithm motivates to implement the algorithm in research prototype central protection system of ABB.

8.3. Some practical implementation issues

The practical issues which are important in implementation of a new algorithm for protection of the medium voltage network are as follows:

- How the load variation affects to the behavior of algorithm i.e. in maximum and minimum loading condition of the feeders.
- How the disconnection of any feeder from the main network affects to the behavior of algorithm.
- How the faults in the network affects to the behavior of algorithm.

During the first situation i.e. changes in load, there is no significant effect on the limits values used in the algorithm. When the load changes, load current changes and hence the initial values for finding the change in the phase currents and sum of phase currents after the fault are just changed. In other words, only the initial values of magnitude and angles of phase currents are changed and they should be updated in the algorithm so that change in currents should be calculated easily.

In the second situation when any feeder is disconnected then it means that capacitive current due to the earth fault from that feeder is not taking part in the earth fault on other feeder. In this way the limits values will be changed according to the amount of capacitive currents of the feeder which is disconnected. The value of the magnitude of capacitive current is subtracted from each value of the magnitude limits and vice versa. Whereas the value of the angle limit is changed insignificantly, this can be neglected.

In the third situation, the algorithm works fine because algorithm is dealing with all possible types of faults on the medium voltage network already.

9. Conclusion

This chapter provides the opportunity to peer into the main objectives and the goals achieved in this thesis. Moreover the future prospects of the developed algorithm, discussed in this chapter, will lead us to the development of better protection system for the distribution network; hence the target of providing safe and reliable power to users can come true.

9.1. Main results

The main objective of this thesis was to develop a method to detect the cross country earth faults. The method should be easy to implement in the systems which are based on the concept of the centralized protection and control and also it must use the protection functions available in the centralized protection and control. Intelligent electronic device (IED) as developed by ABB, have the protection function for the earth faults named as directional earth fault protection (DEFPTOC) and are the part of the centralized protection systems. So the objective of thesis become clearer that is to develop the detection algorithm for the cross country faults and make it compatible with IEDs of ABB for the centralized protection systems.

In cross country fault, when one phase experiences the earth fault then at the same time other phase also undergoes the earth fault at the different location. When both the faulty phases are located on same feeder but at different locations then this is known as cross country fault on same feeder but if one faulty phase is on one feeder and other faulty phase is on other feeder then it is called as cross country fault on different feeders. In cross country faults both the earthed faulty phases are short circuited through the ground. In this way, the cross country faults are type of earth faults in which the faulty phase are short circuited through the ground. Traditionally the DEFPTOC is designed to protect the feeders from the earth faults but it has been observed that DEFPTOC is failed to detect the both the faulty phases residing on same or different feeders at the same time as in cross country fault on same or different feeders. Moreover, the cross country fault has the short circuit current between the faulty phases through the ground and DEFPTOC is incapable of handling the short circuit current. So DEFPTOC seems to fail in dealing with cross country faults. This leads to the research of the method to detect the cross country faults.

The developed method is the expansion of the DEFPTOC in the sense that it needs the triggering signal from DEFPTOC in order to start the procedure for finding the cross country faults on every feeder of the medium voltage network. Previously the DEFPTOC was failed to detect two faulty feeders simultaneously as in the case of cross country fault on the different feeders and detects only one fault on one feeder. Hence this problem can be solved in this way that when DEFPTOC detects only one fault then

it should trigger the algorithm on rest of feeders. This method uses the phase currents and sum of phase currents (i.e. $I_A + I_B$, $I_B + I_C$ and $I_A + I_C$) for the detection of the cross country faults. The summary of steps involved in this method is as follows

1. Get triggered from the DEFPTOC
2. Use sum of phase currents to find whether the feeder is under a fault or not
3. Use phase currents to find the number of faulty phases and their names
4. Use sum of currents to find whether the fault on the feeder is type of earth fault or not
5. Use sum of currents and verify for values of defined limits to find the cross country fault.

The step two is needed because when the DEFPTOC triggers the method on all the feeders then all the feeders cannot be faulted at the same time then it differentiated the faulty feeders from healthy feeders and to avoid action on healthy feeders. The fourth step plays an important role in a way that when the method is running on all the feeders then there is chance that one feeder experiences a short circuit fault at the same time there is an earth fault on the other feeder. So the fourth step successfully separates the earth fault from the short circuit fault.

The method has been tested with the several possible cases discussed in chapter 6 with earth fault resistance varying from 0 to 500 ohms and short circuit fault resistance varies from 0 to 20 ohms in the PSCAD and RTDS. Moreover it has been tested not only for the overhead MV feeders but for the MV cable feeders too. The method works fine in all cases but for some values of the earth fault resistance (i.e. 10-30 ohms), for both the phases and for the small distance with these resistances, the cross country fault is detected as phase to phase to earth fault. Otherwise it works fine. The real advantage of the method is that it reduces the time of operation of the DEFPTOC for the cross country fault and it is easy to implement in centralized protection system because of its 'if and else' structure.

In the nutshell, the method successfully detects the cross country faults and in result improves the protection of medium voltage networks against them by the centralized protection systems

9.2. Recommendations for future work

The method has been designed for the neutral isolated MV networks. There is need of making this method compatible for the medium voltage compensated networks too. The method wrongly detects the cross country fault as phase to phase to earth fault when the earth fault resistances for both the faulty phases are small with small distance between them. This leads for the need of improvement of method for these cases too in future. The methods of finding the values of the limits are tedious so better mathematically modelling is required for finding the values of limits and hence make them more rigid for the practical cases.

References

- [1] Nikander A., Novel Methods for Earth Fault Management in Isolated or Compensated Medium Voltage Electricity Distribution Networks. Dissertation, Tampere 2002, Tampere University of Technology, Publication 363, 200 p.
- [2] Anon., Harmonization Document HD 637 S1: Power Installations exceeding 1 kV a.c. European Committee for Electromechanical Standardization (CENELEC), 1999, 107 p.
- [3] Järventausta P., Feeder Fault Management in Medium Voltage Electricity Distribution Networks. Dissertation, Tampere 1995, Tampere University of Technology, Publication 164, 263 p.
- [4] Lakervi E., Partanen J., Sähköjaketekniikka. Helsinki 2008, Otatieto, 294 p, ISBN 978-951-672-357-3
- [5] Lakervi E., Holmes E., Electricity Distribution network design(2nd edition). London 1995, Peter Peregrinus Ltd., 322 p., ISBN 0-86341-308-0
- [6] Lehtonen M., Hakola T., Neutral Earthing and Power System Protection. Vaasa 1996, ABB transmit Oy, 118 p. ISBN 952-90-7913-3
- [7] Haase H., Taimisto S., Distribution compensation of earth fault current in medium voltage networks. Proceedings of the 8th International Conference on Electricity Distribution (CIRED 1985), IEE Conference Publication No. 250, Part 1, Brighton, UK, May 1985, pp.150-143
- [8] Adamiak M.G., Premerlani W., A new approach to current differential protection for transmission lines, Protective Relaying Committee Meeting of electric council of new England, Portsmouth, NH, OCT 1998, General Electric Publication, 16 p. Available at: <http://store.gedigitalenergy.com/faq/documents/l90/ger-3981.pdf>
- [9] Lin X., Weng H., Wang B., Identification of cross-country fault of power transformer for fast unblocking of differential protection, IEEE transactions on power delivery, Vol. 24, No. 3, JULY 2009, pp.1079-1086.

- [10] Rebizant W., Solak K., Analysis of differential protection response for cross-country faults in transmission lines,, Proceedings of the International Symposium on Modern Electric Power Systems (MEPS), Wroclaw 20-22 Sept. 2010., IEEE, 4 p.
- [11] Bi T., Li W., Xu Z., Yang Q., First-zone distance relaying algorithm of parallel transmission lines for cross-country grounded fault, IEEE transactions on power delivery, Vol. 27, No. 4, OCTOBER 2012, pp. 2185-2192.
- [12] Thoke A.S., Patel R.N, Koley E., Jain A., Intercircuit and cross-country fault detection and classification using artificial neural network, Kolkata, 2010, IEEE India Conference (INDICON), 2010, 4 p.
- [13] Hakala Tomi., Prioritization principles for the reinvestment plan of low loaded parts of the rural medium voltage network, M.Sc. Thesis, Tampere 2013, Tampere University of Technology, 78 p.
- [14] Valtari J., Hakola T., Verho P., Station Level Functionality in Future Smart Substations. 2010, Nordac.
- [15] Valtari J., Verho P., Hakala-Ranta A., Saarinen J., Increasing Cost-efficiency of Substation Automation Systems by centralized protection functions, Proceedings of 20th International Conference on Electricity Distribution (CIRED 2009), CIRED paper no. 0764, Prague, 08/06/2009–11/06/2009, 4 p.
- [16] Kettunen Erkka, Configuration of Electrical Substation Computer. Master of Science Thesis, Tampere 2011, Tampere University of Technology, 47 p.
- [17] Mörsky J. Relesuojaustekniikka. (2. Painos), Hämeenlinna 1993, Otatieto. 459 s.
- [18] Nordström L., IEC 61850 and Interoperability in Smart Grid. June 2012, Royal Institute of Technology, Stockholm. Unpublished Lecture. 55 p.
- [19] Werner S. IEC 61850 Introduction Extended Version. March 2012.AMA Group. Unpublished Presentation. 121 p.
- [20] IEC 61850-8-1. Communication networks and systems in substations – Part 8-1: Specific Communication Service Mapping (SCSM) – Mappings to MMS (ISO9506-1 and ISO 9506-2) and to ISO/IEC 8802-3. 1st ed. 2004, International Electrotechnical Commission. 133p.

- [21] Brunner C. IEC 61850 Process Bus – Challenges and Benefits. UT Innovation, Switzerland.
- [22] IEC 61850-2. Communication networks and systems in substations – Part 2: Glossary. 1st ed. 2003, International Electrotechnical Commission. 42 p.
- [23] Mackiewicz R. Overview of IEC 61850 and Benefits. [WWW]. [Cited 23/02/2011]. Available: http://140.98.193.141/portal/cms_docs_pes/pes/subpages/meetings- folder/T_D_2005_2006/Tuesday/pn10/05TD0235.pdf.
- [24] IEC 61850-1. Communication networks and systems in substations – Part 1: Introduction and overview. 1st ed. 2004, International Electrotechnical Commission, 37 p.
- [25] Hakala-Ranta A., Rintamäki O., Starck, J., Utilizing possibilities of IEC 61850 and GOOSE, Prague, 08/06/2009–11/06/2009. 2009, CIRED.
- [26] ABB's IED 'REF 630 series' Technical Manual, ABB. [WWW]. [Accessed on 15.02.2014]. Available at: [http://www05.abb.com/global/scot/scot229.nsf/veritydisplay/03362e7585be8d6bc1257a8c001bd14a/\\$file/RE_630_tech_756508_ENd.pdf](http://www05.abb.com/global/scot/scot229.nsf/veritydisplay/03362e7585be8d6bc1257a8c001bd14a/$file/RE_630_tech_756508_ENd.pdf)
- [27] EMTDC User's Guide, Manitoba HVDC Research Centre, Canada, April 2005. [WWW]. Available at: https://hvdc.ca/uploads/ck/files/reference_material/EMTDC_User_Guide_v4_2_1.pdf
- [28] MATLAB's datasheet, MathWorks Inc., Sweden, September 2012. [WWW]. Available at: <http://www.mathworks.se/products/datasheets/pdf/matlab.pdf>
- [29] RTDS Technologies (real time digital simulator) hardware's webpage. [WWW]. [Accessed on 01.06.2014]. Available at: <http://www.rtds.com/hardware/hardware.html>
- [30] RTDS Technologies (real time digital simulator) RSCAD software's webpage. [WWW]. [Accessed on 01.06.2014]. Available at: <http://www.rtds.com/software/rscad/rscad.html>
- [31] Raipala Ontrei, Real time simulations of active distribution network. M.Sc., Thesis. Tampere 2009, Tampere University of Technology, 138 p.

- [32] Phadke A.G., et.al., Comtrade: A new standard for common format for transient data exchange, IEEE Transactions on Power Delivery, vol. 7, No. 4, October 1992, pp. 1920-1926.
- [33] Valtari J., Centralized architecture of the electricity distribution substation automation – benefits and possibilities. Dissertation, Tampere 2013, Tampere University of Technology, Publication 1122, 134 p.
- [34] AXAL 21 kV cable data sheet, [WWW]. Available at: <http://elteccable.be/uploads/AXAL-TT-PRO-1220-kV.pdf>
- [35] IEC 61850 standard, Wikipedia. [WWW]. [Accessed on 25.05.2014]. Available at: http://en.wikipedia.org/wiki/IEC_61850.
- [36] Hindle P.J., Chapman K.G., Conventional directional overcurrent & earth fault protection – not always straight forward, Seventh International Conference on developments in Power System Protection (IEE 2011), Amsterdam 09-12 April 2011., IET, pp. 543-546

